

FLY TYP-22

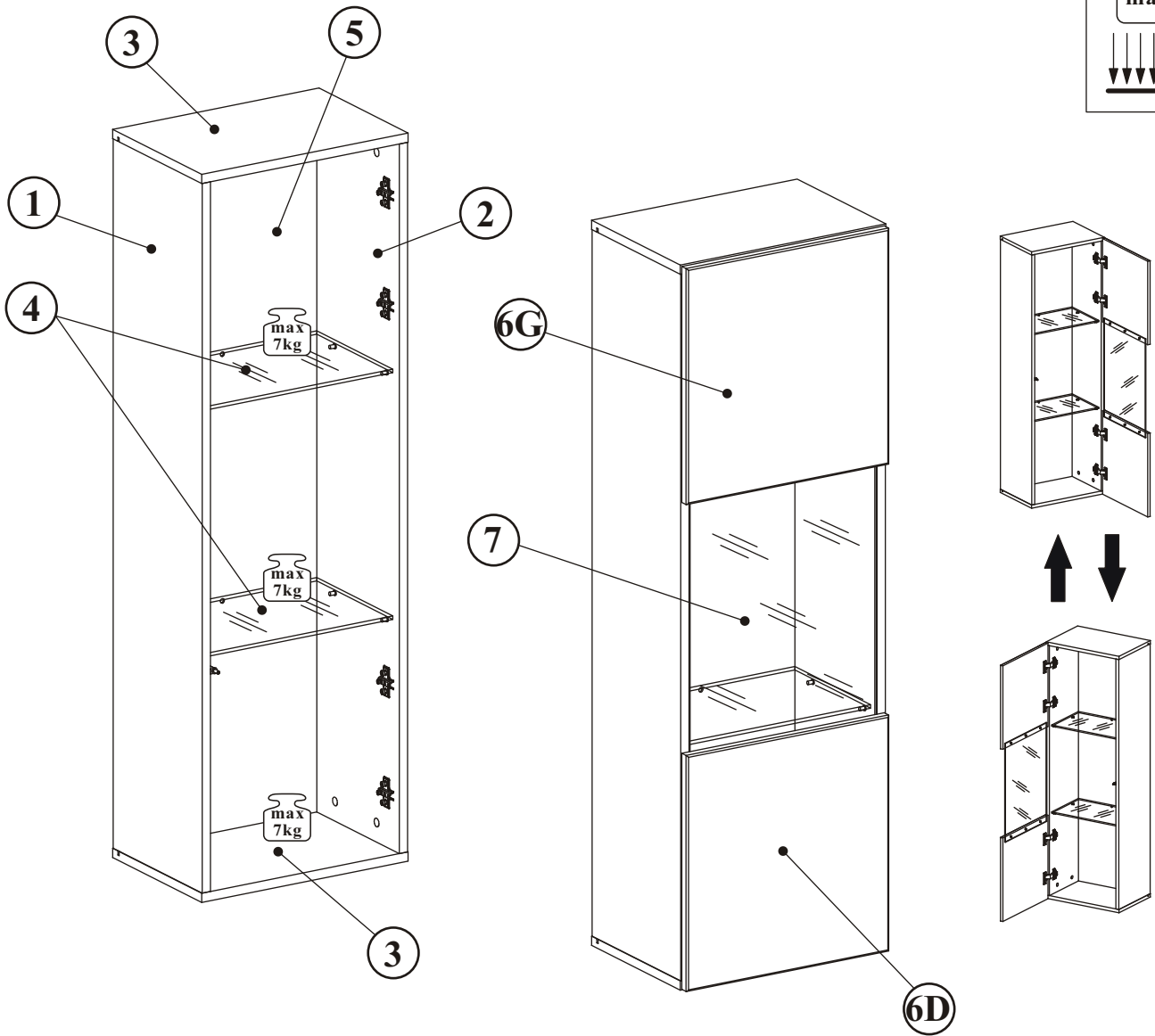

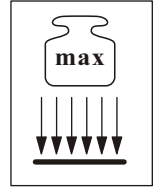

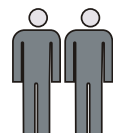





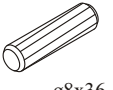
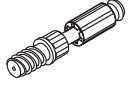

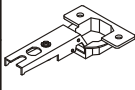
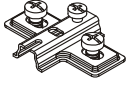
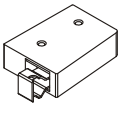
NO	Dim.		Col.-No	Qty
1	1228	274	1	1
2	1228	274	1	1
3	400	274	1	2
4	364	234	1	2
5	1240	378	1	1
6G	394	410	1	1
6D	394	410	1	1
7	485	362	1	1

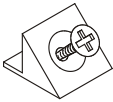

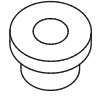
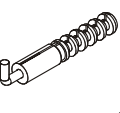
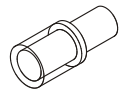
70 min

FLY TYP-22

A1 x8 	B4 x8 	B5 x8 	G5 x8 	E1 x4 Ø26 H=0 	E2 x4 H=0 
ZR1 x2 	D6 x4 USØ3,5x30 	S1 x10 	D10 x10 USØ3,5x13 	UP13 x6 UPØ3x16 	P2 x6 
KR2 x2 	G20 x8 	G2 x1 	Z2 x8 ø5 	T1 x1 	

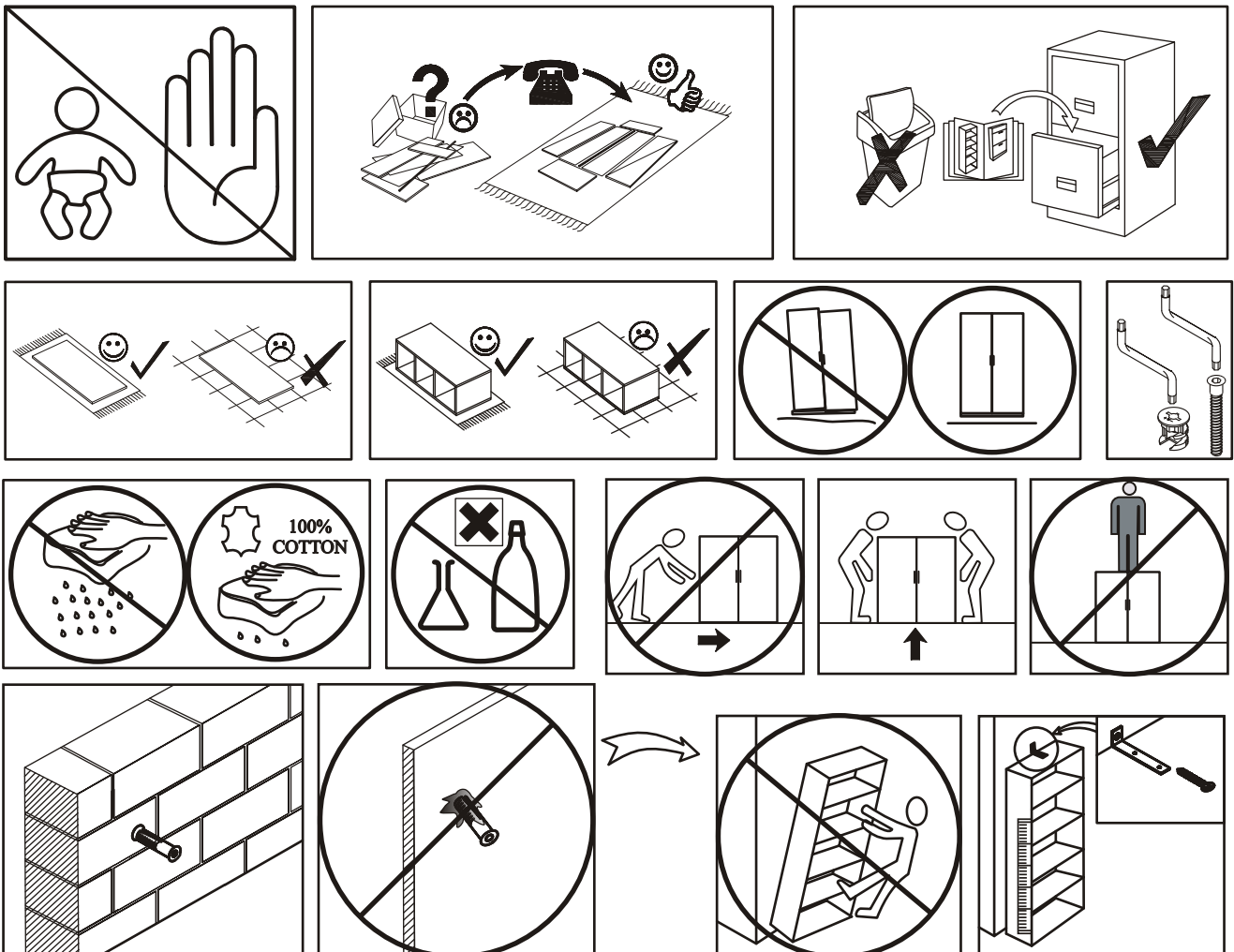
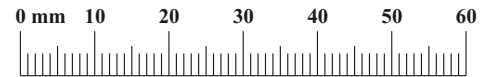

FLY TYP-22

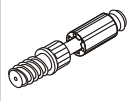
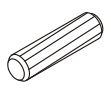
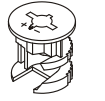
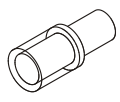
B4		A1		B5	
x8		x8	ø8x36	x8	ø15x12
			G20		
			x8		

1

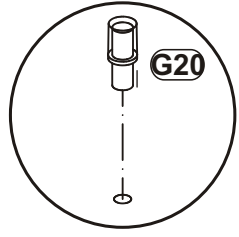
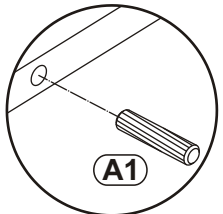
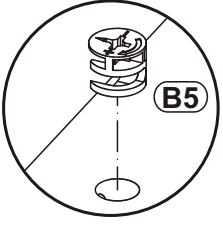
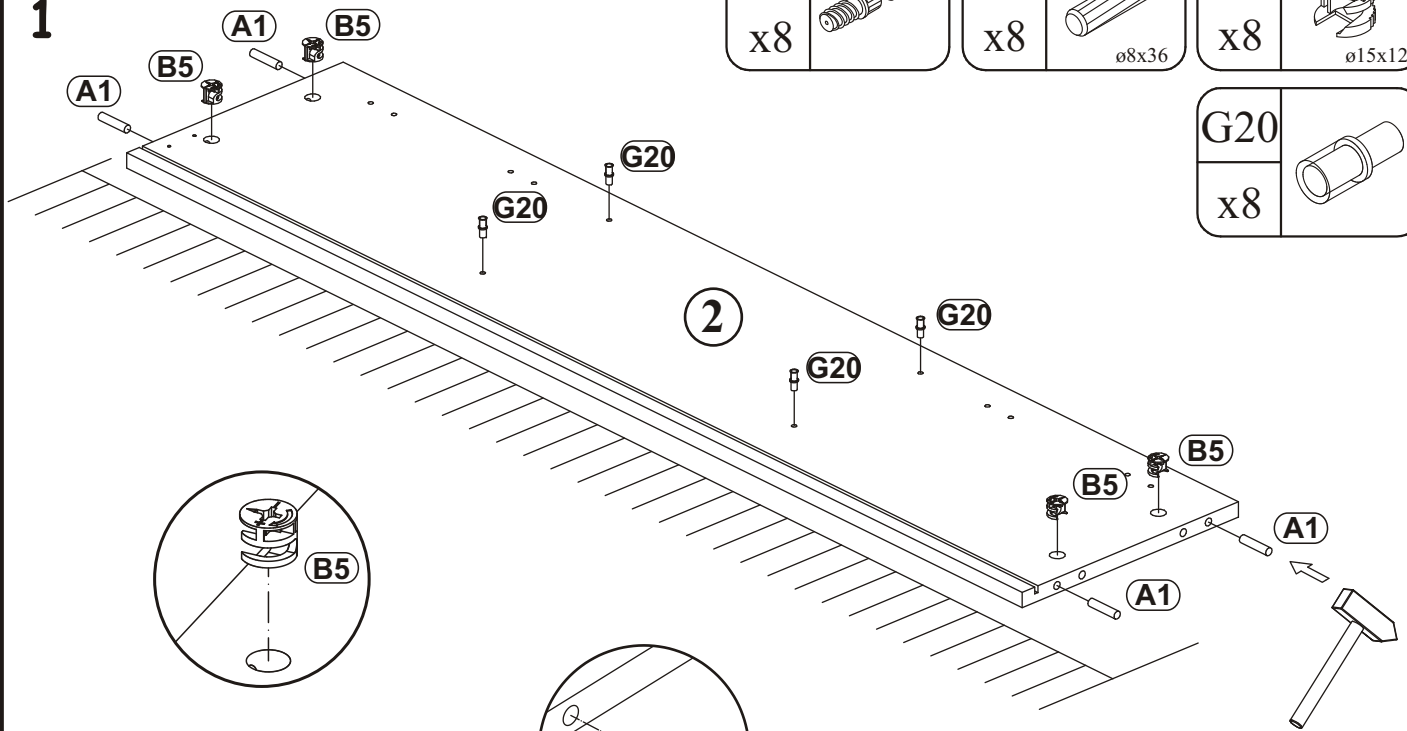

2

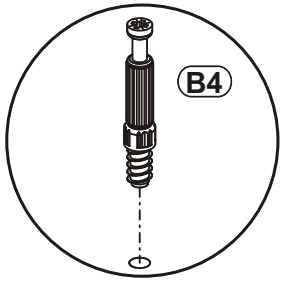
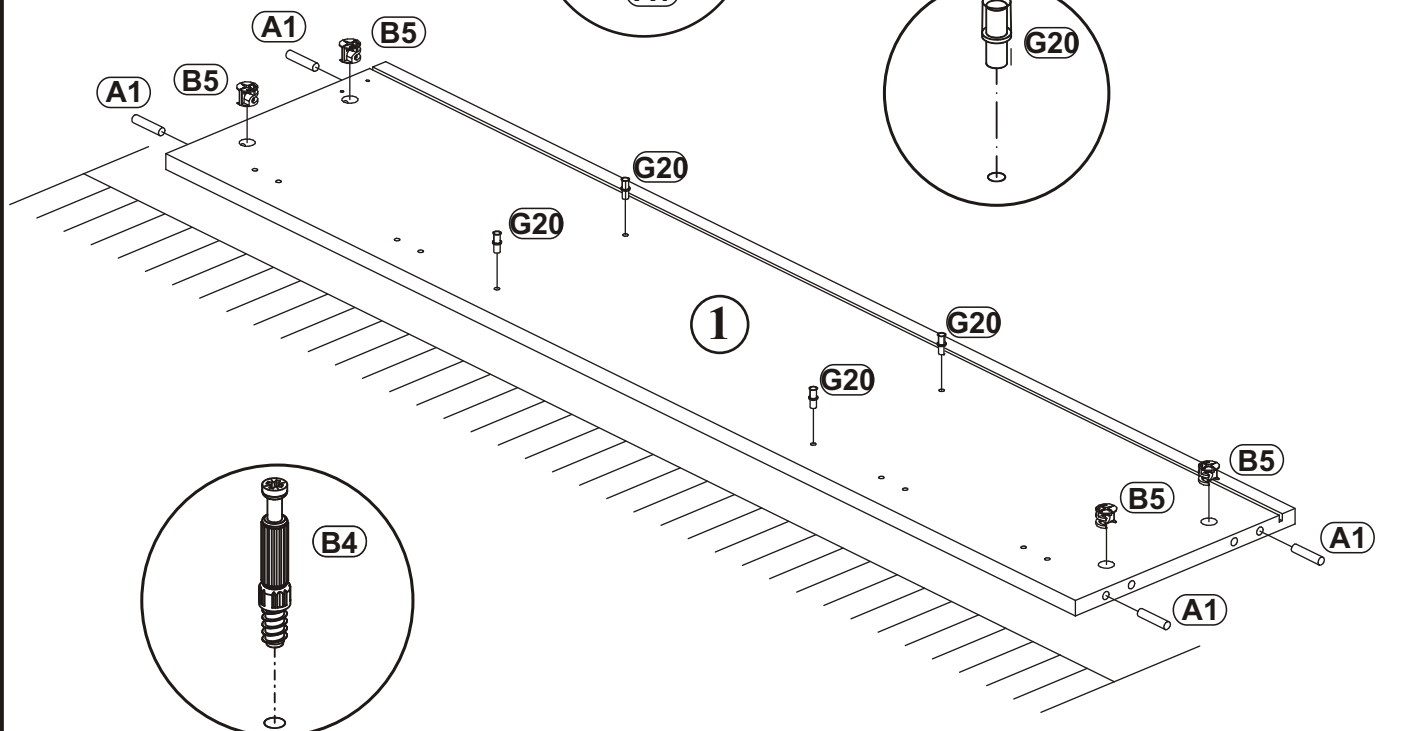

1

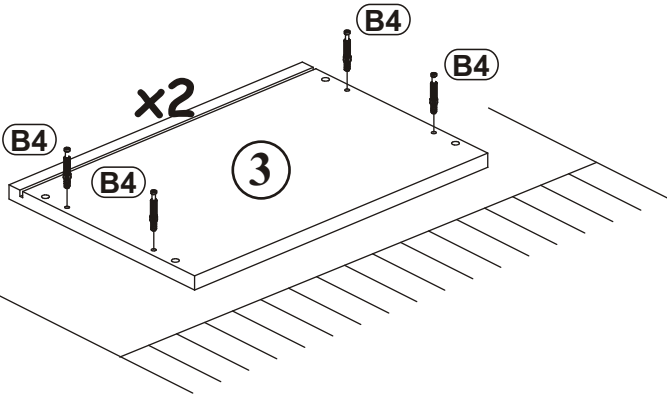

FLY TYP-22

2

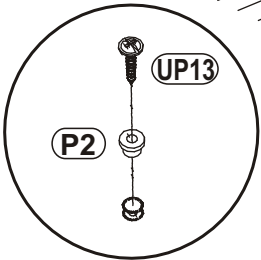
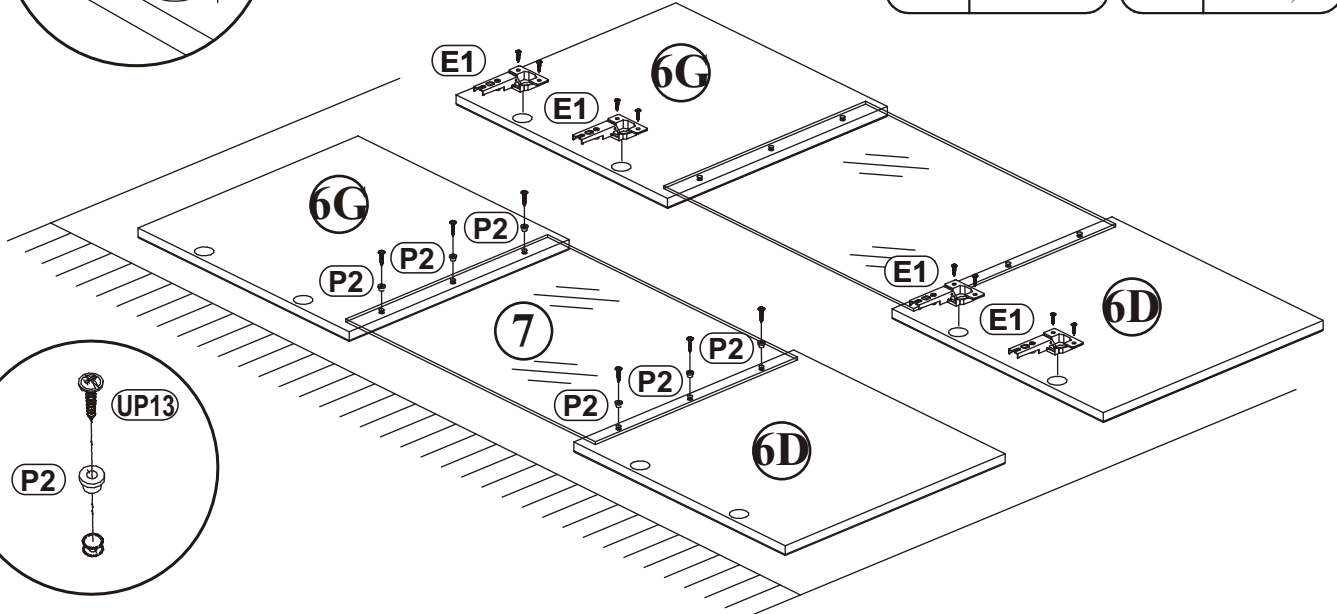
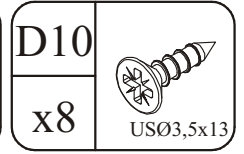
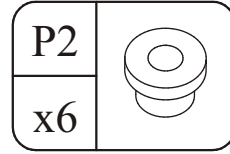
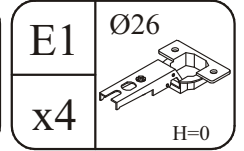
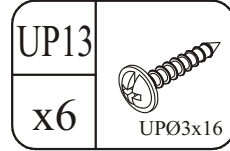
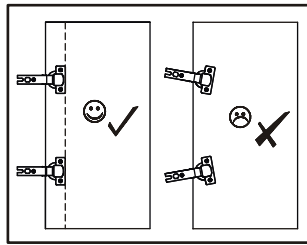
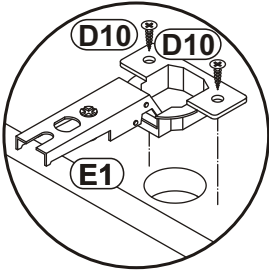

3

a)

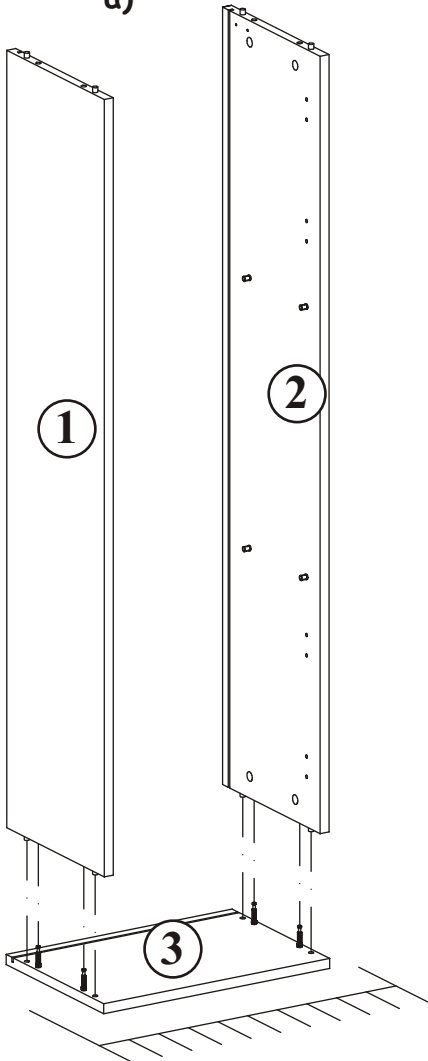

b)

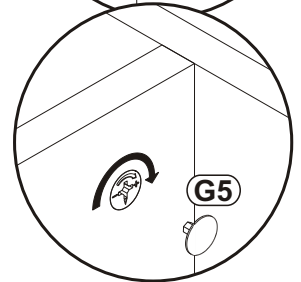
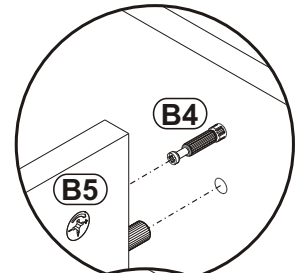
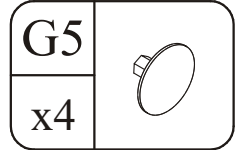
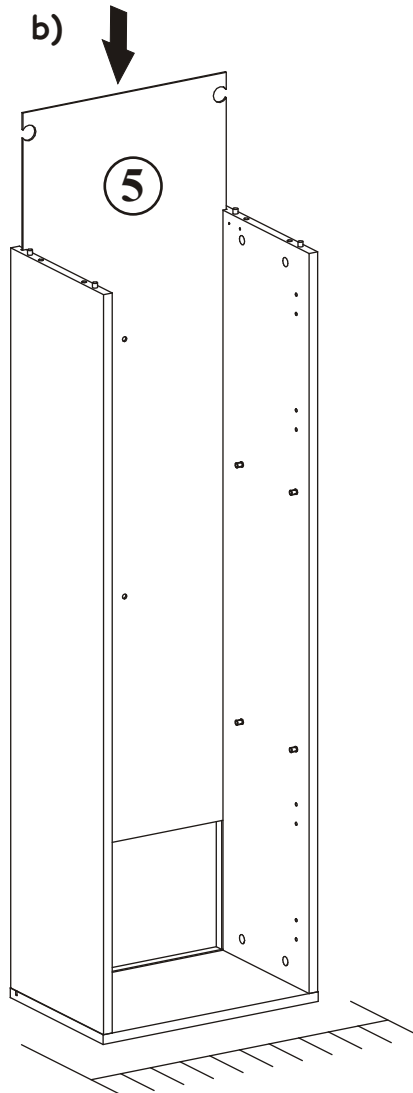

4

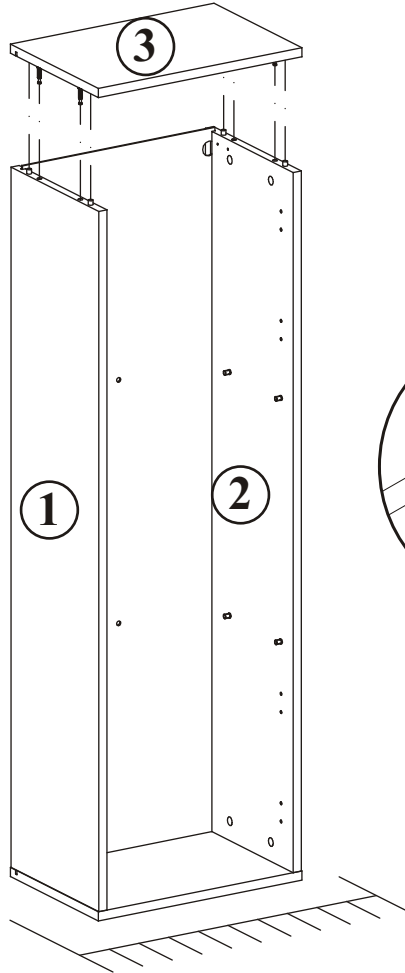

G5	
x4	

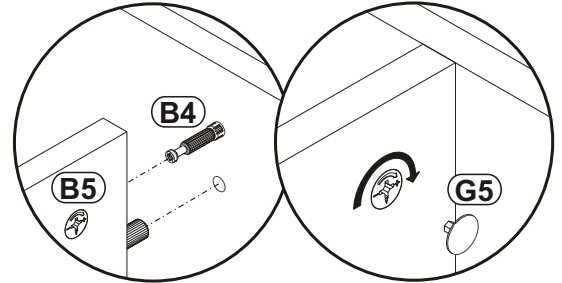

5

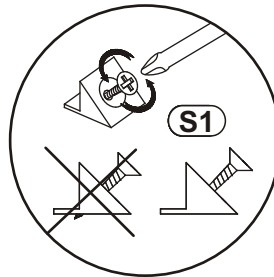
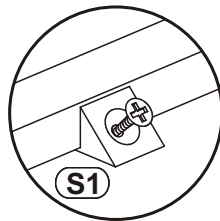

S1	
x10	

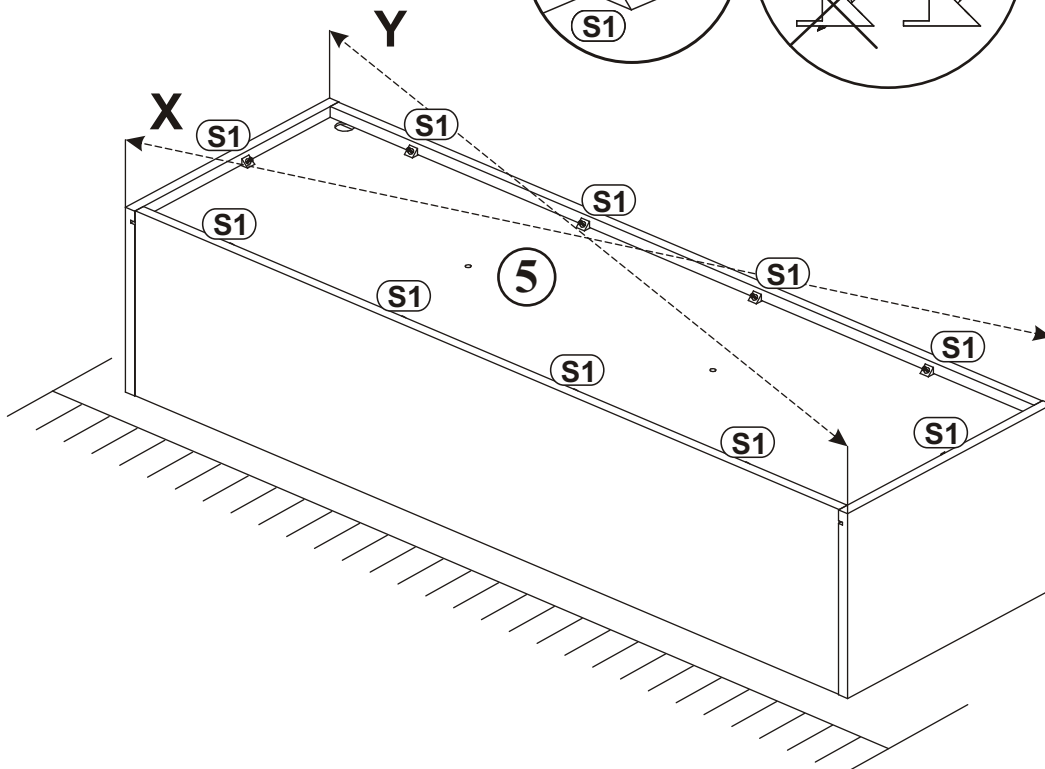

FLY TYP-22

6

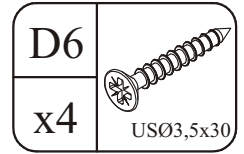
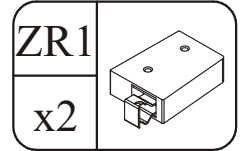
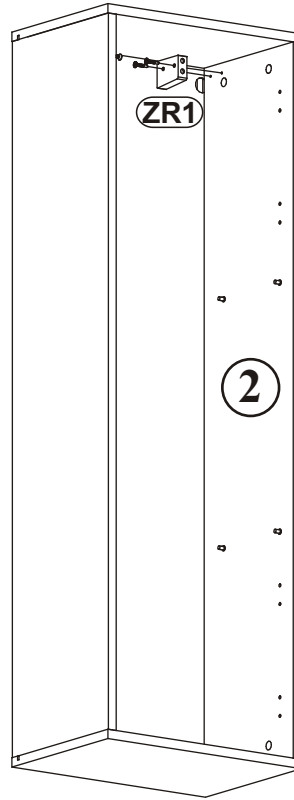
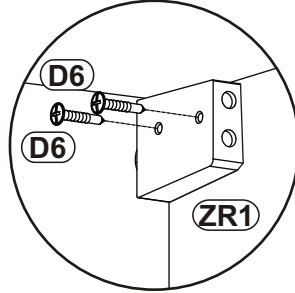
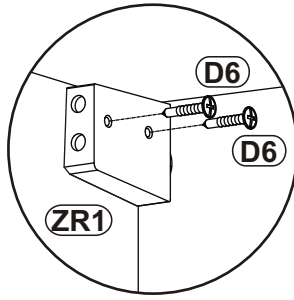
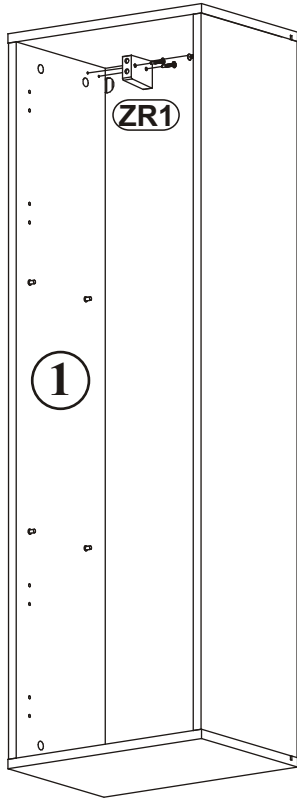

7

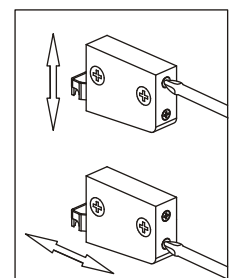
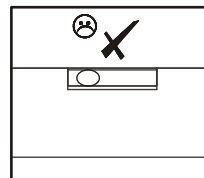
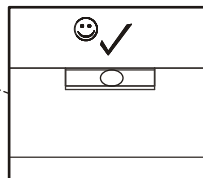
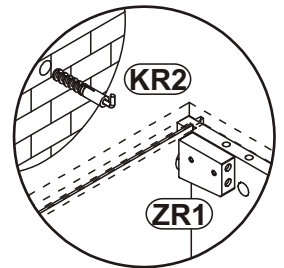
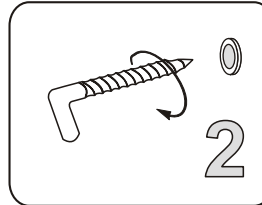
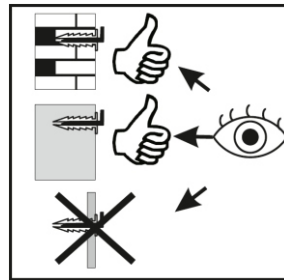
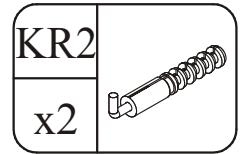
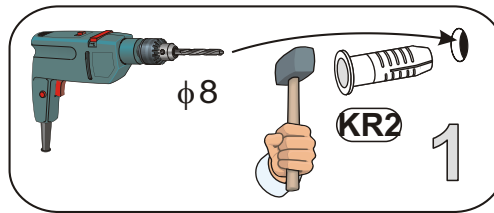
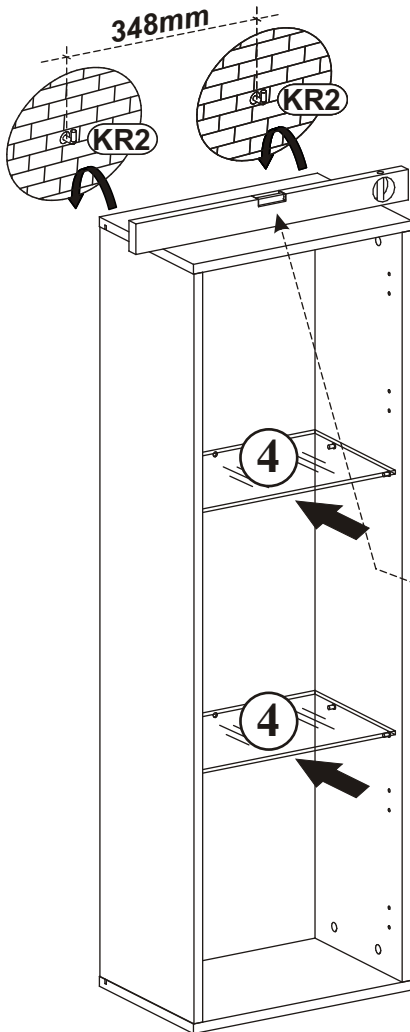

8 - 9

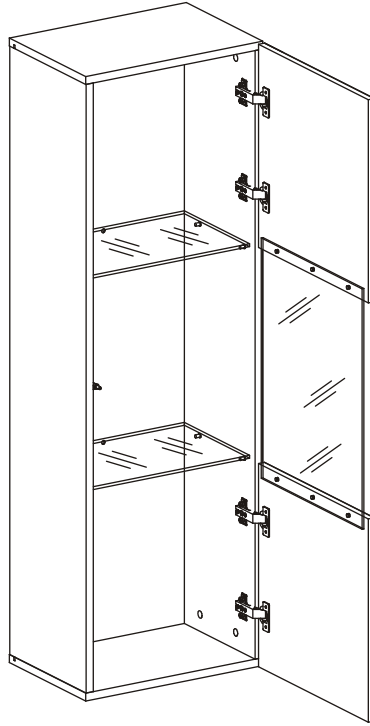

10 - 11

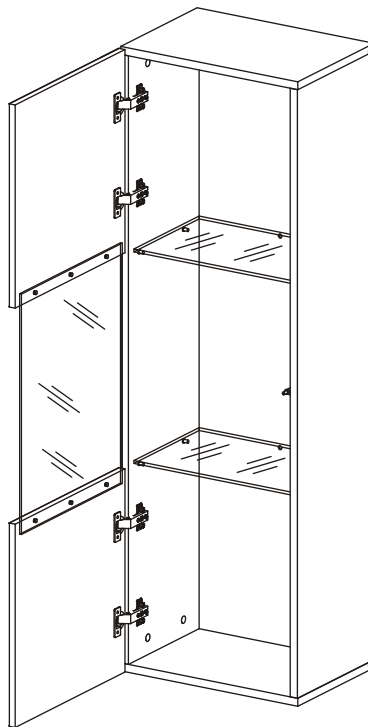

FLY TYP-22

8

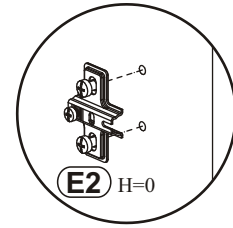
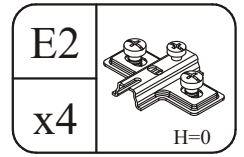
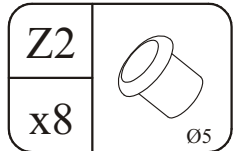
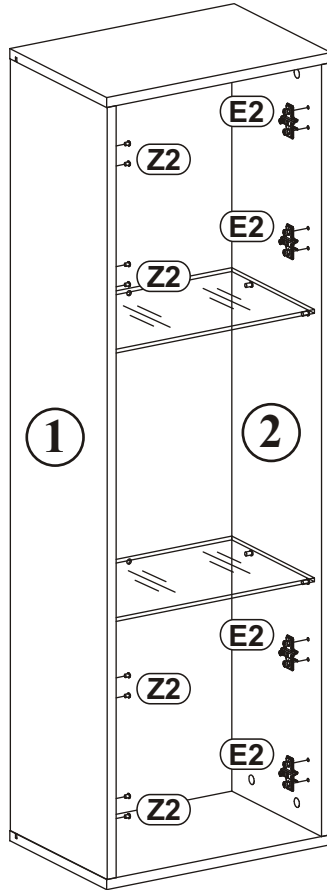
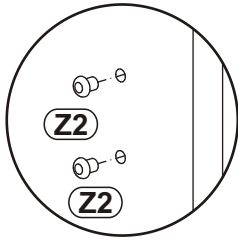
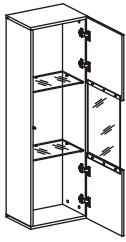

9

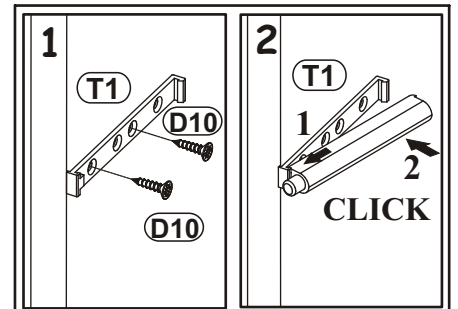
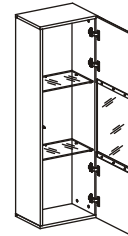
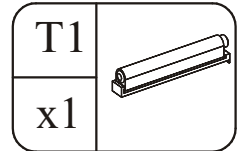
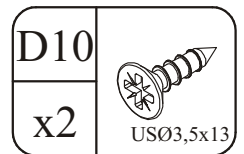
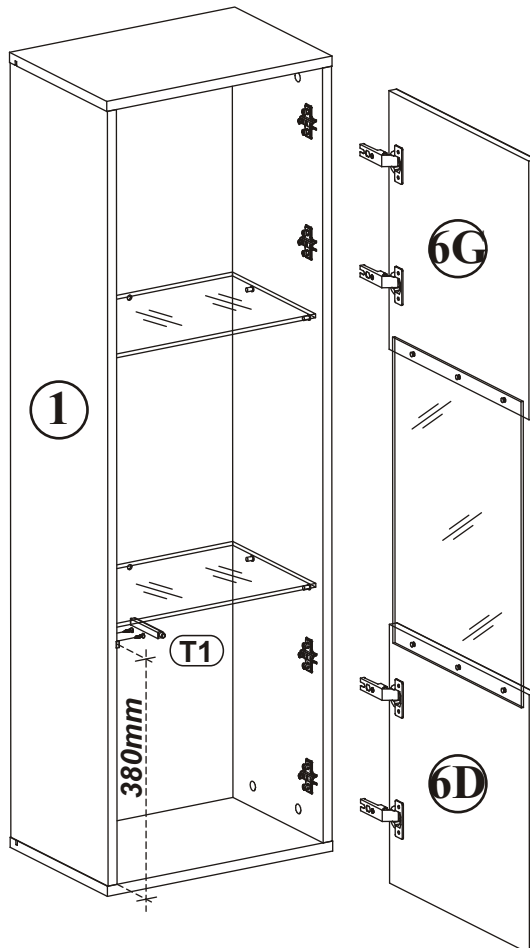
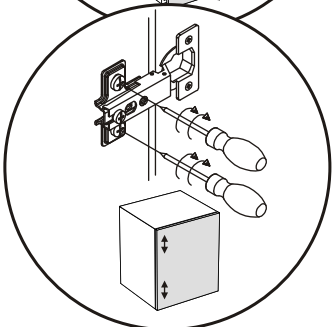
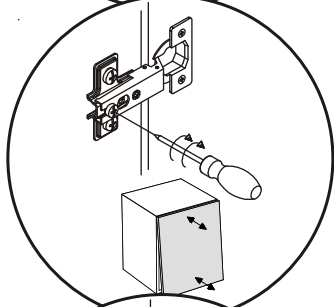
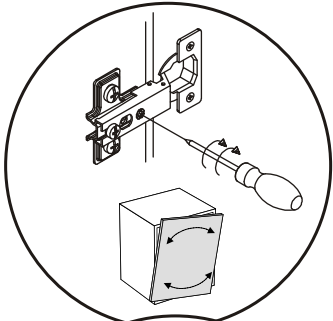

FLY TYP-22

10

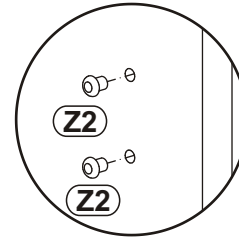
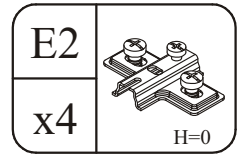
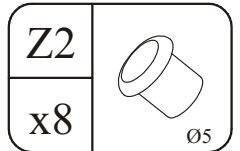
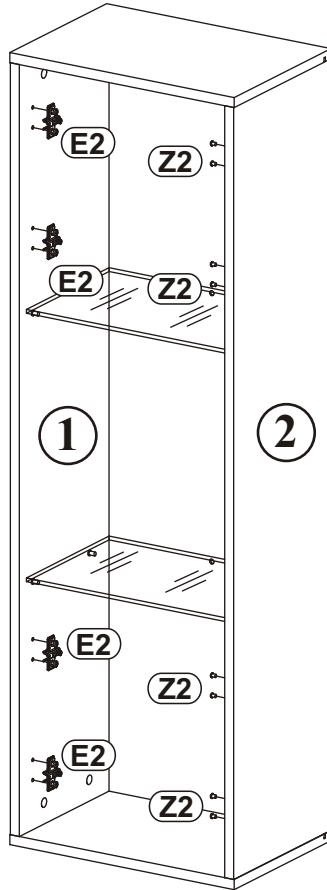
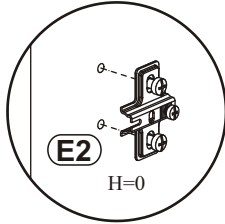
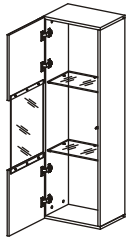

11

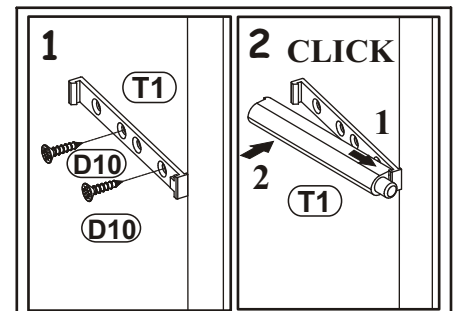
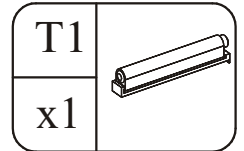
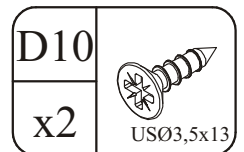
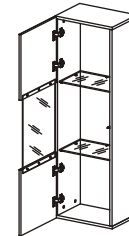
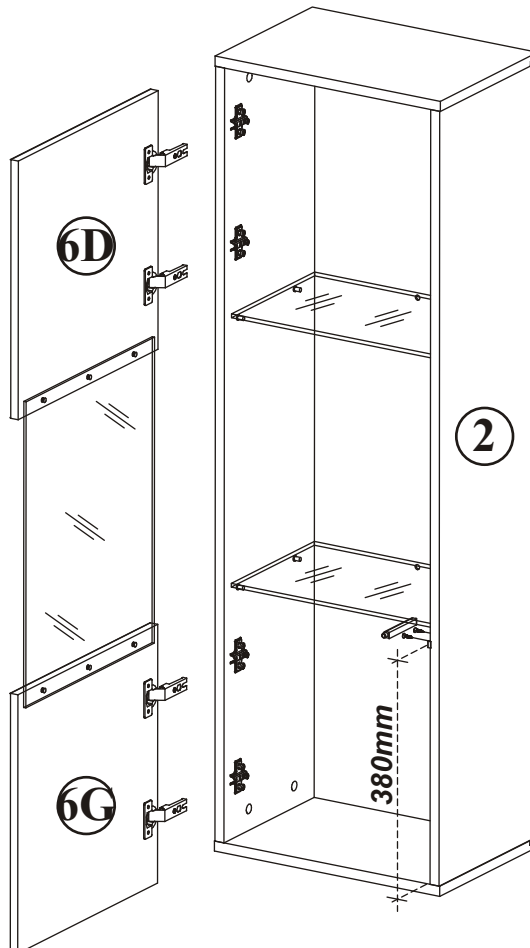
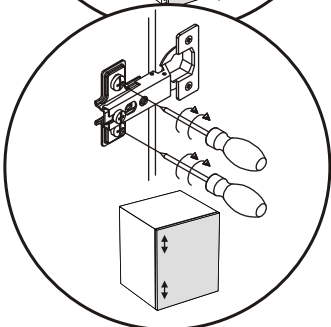
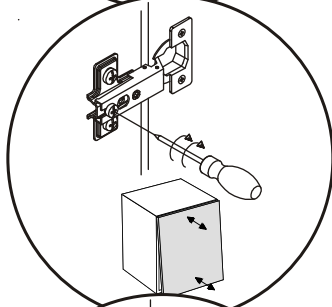
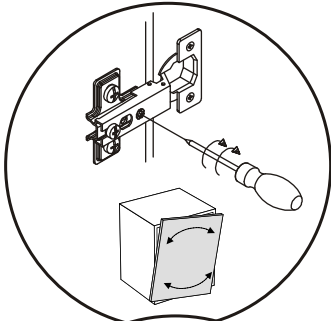

FLY TYP-33

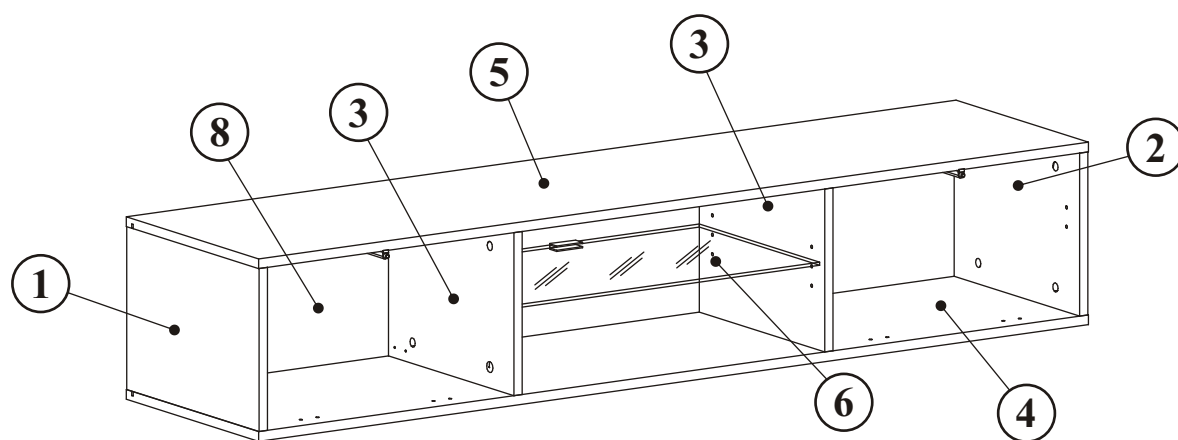
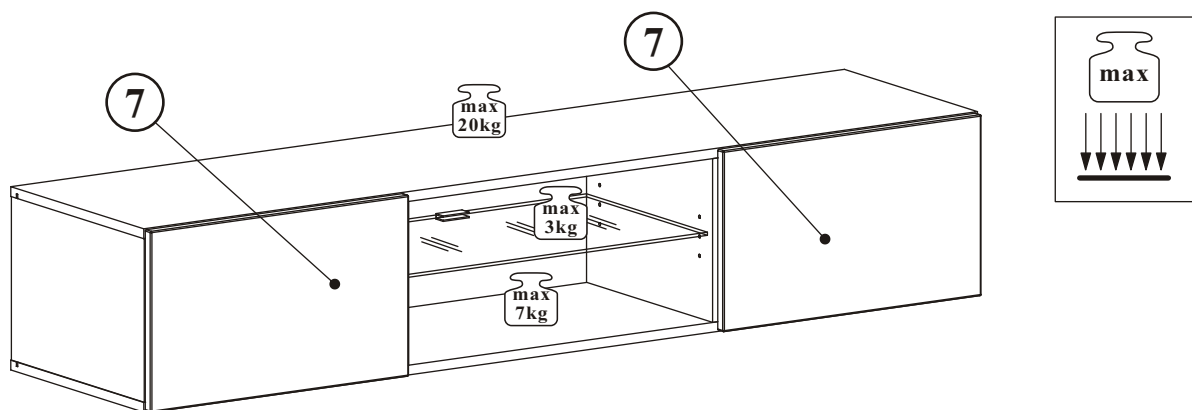



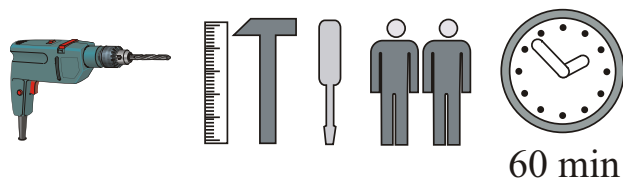





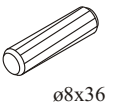
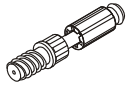

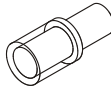
NO	Dim.		Col.-No	Qty
1	268	384	1	1
2	268	384	1	1
3	268	364	1	2
4	1602	384	1	1
5	1602	384	1	1
6	582	349	1	1
7	496	296	1	2
8	1580	280	1	1

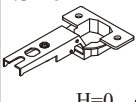
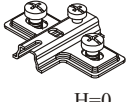
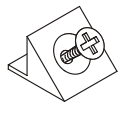

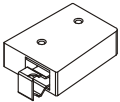

60 min

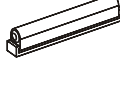
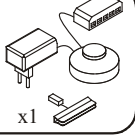
FLY TYP-33

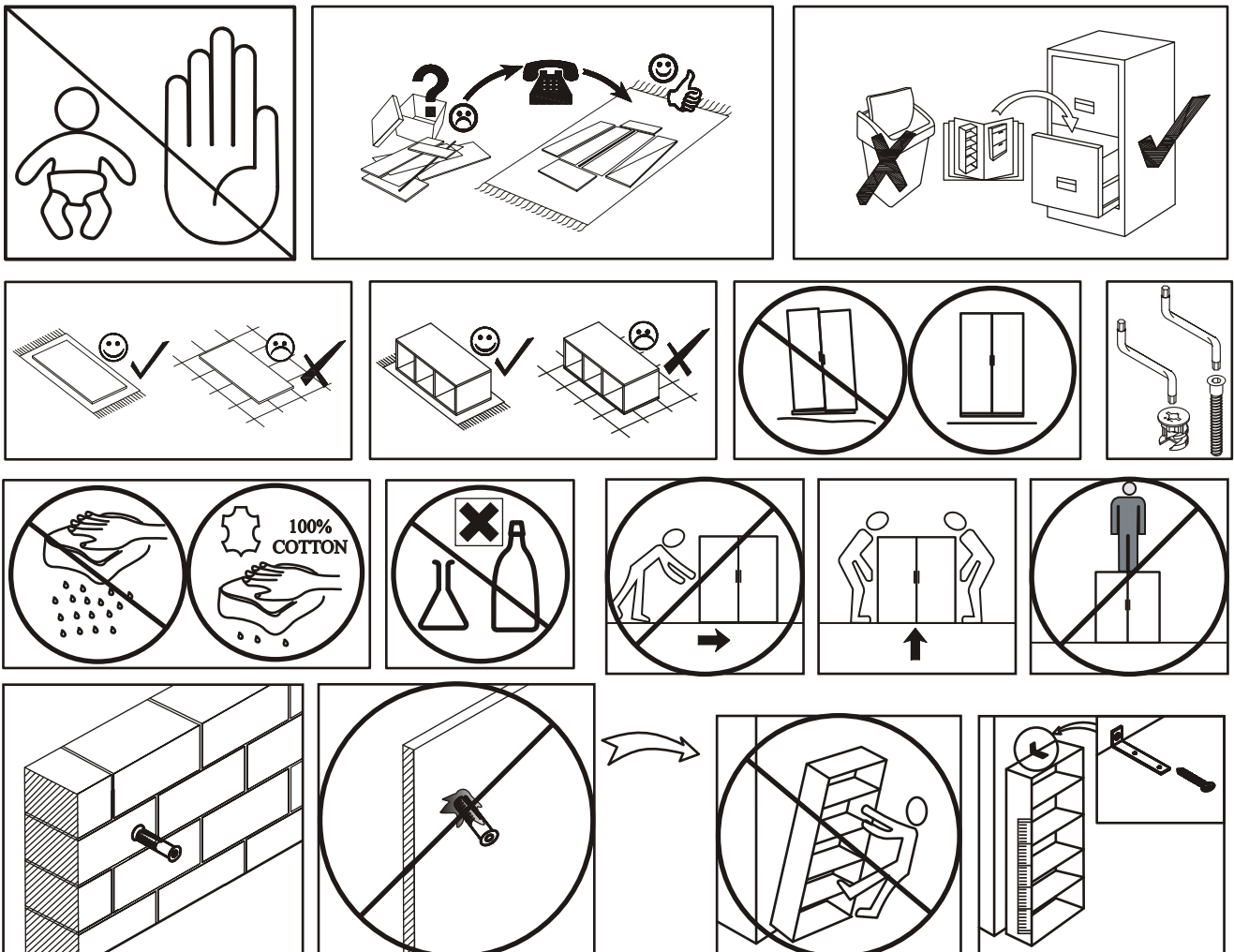
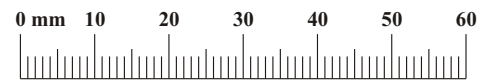
A1 x16 	B4 x16 	B5 x16 	G5 x16 	G20 x4 	G2 x1 
E1 x4 Ø26 H=0 	E2 x4 H=0 	S1 x12 	D6 x8 USØ3,5x30 	D10 x16 USØ3,5x13 	G21 x2 
ZR1 x4 	KR2 x4 	D7 x6 USØ3x16 	T1 x2 	LED x1 x1 	

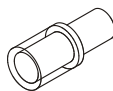
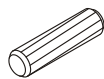

FLY TYP-33

G20		A1		B5	
x4		x16	ø8x36	x16	ø15x12

1

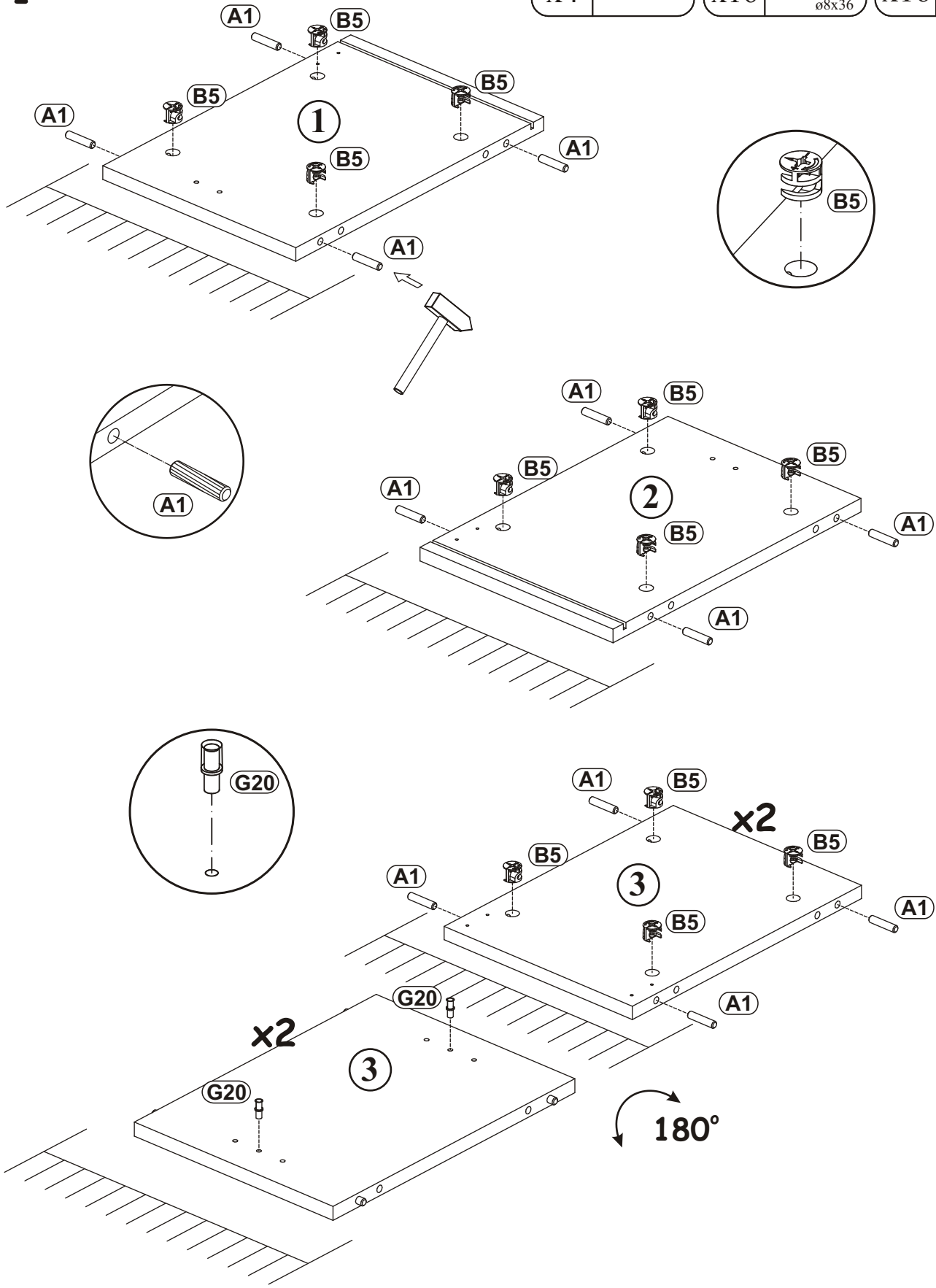

FLY TYP-33

2

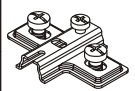
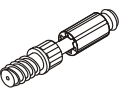
E2		B4	
x4	H=0	x16	

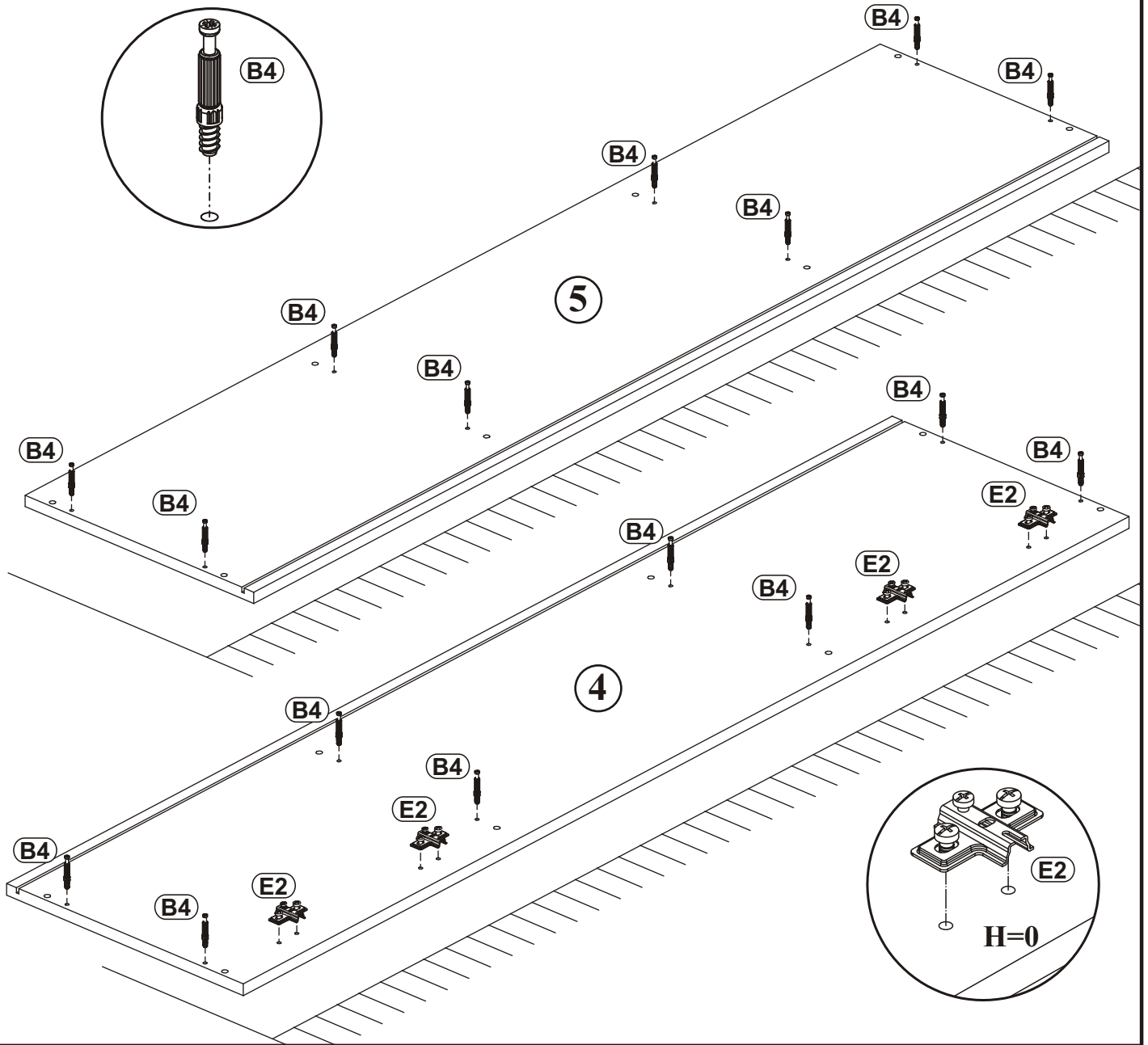

3

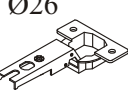
D10		E1	
x8	USØ3,5x13	x4	Ø26 H=0

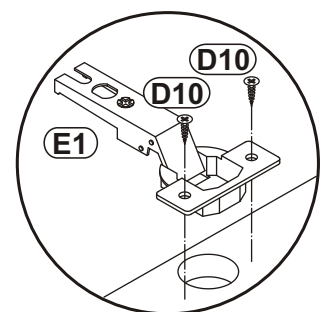
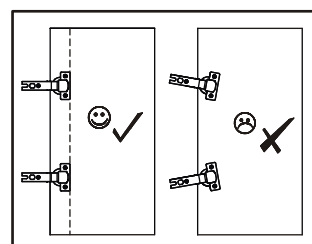
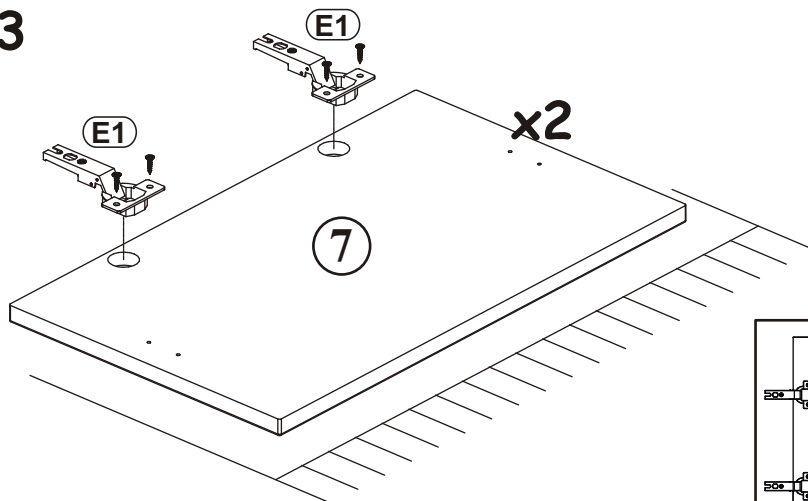

4

a)

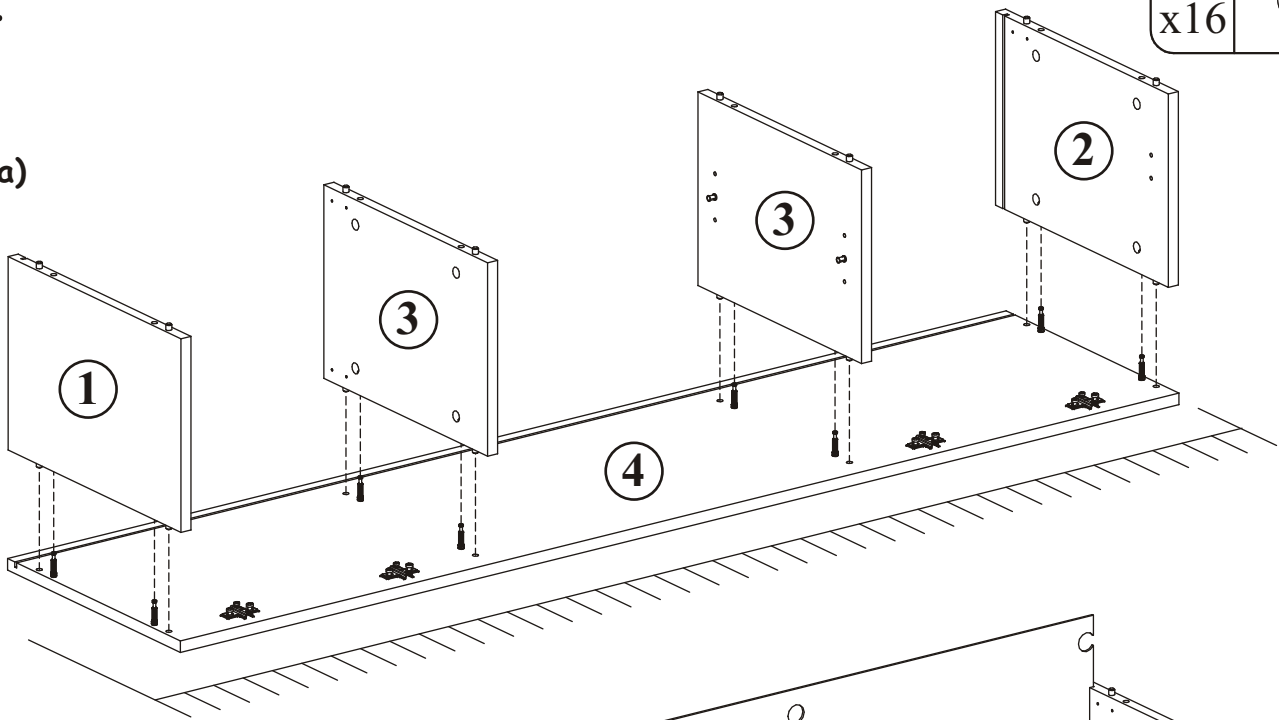

b)

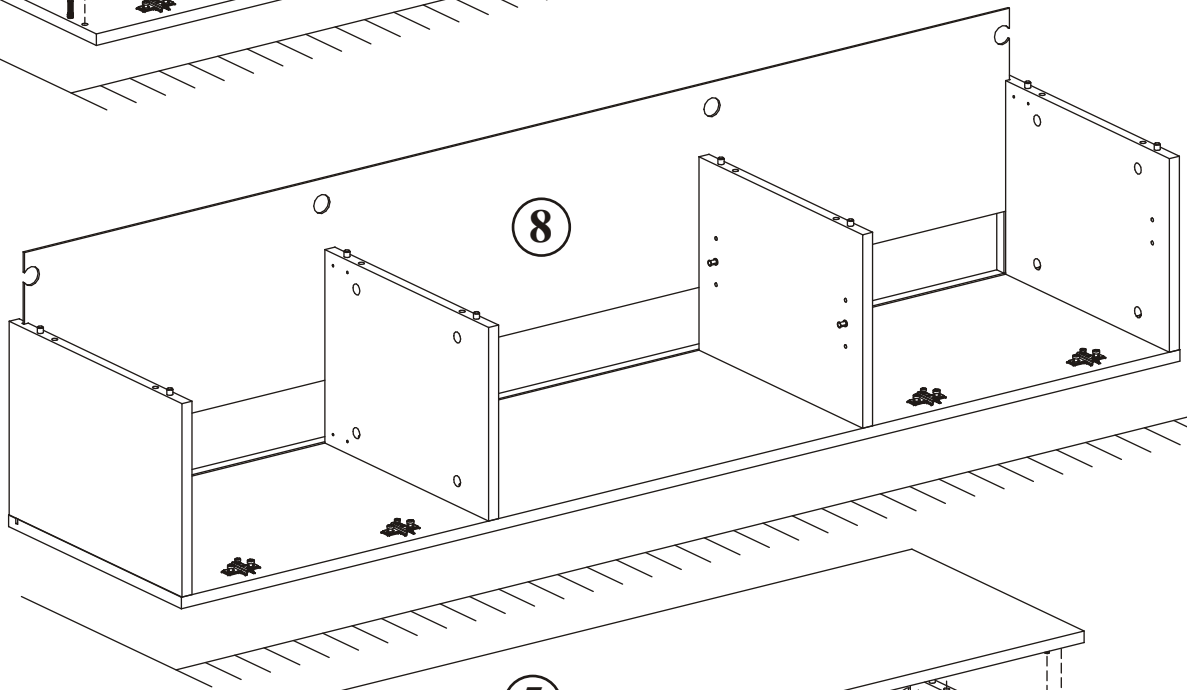

c)

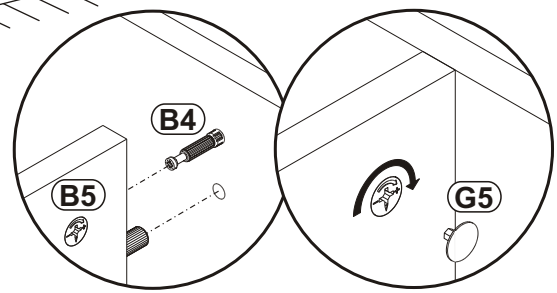
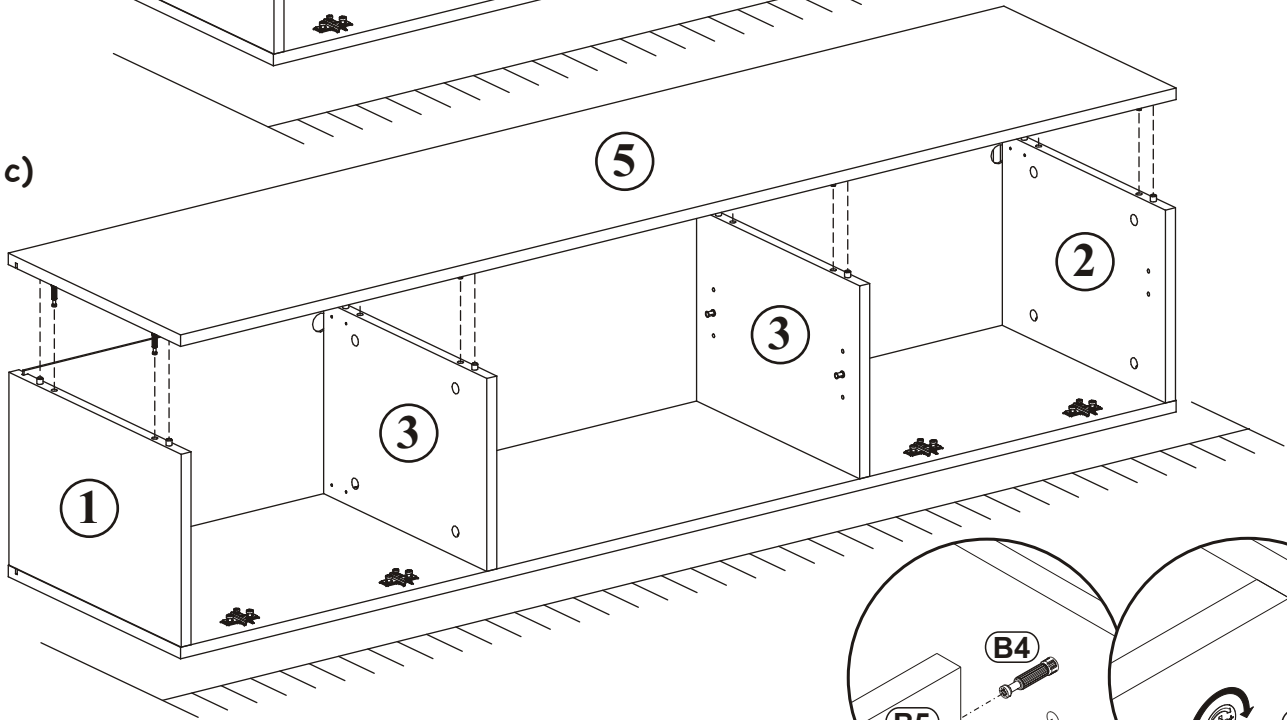

5

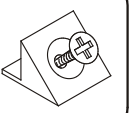
S1	
x12	

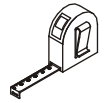

$X=Y$ 90°

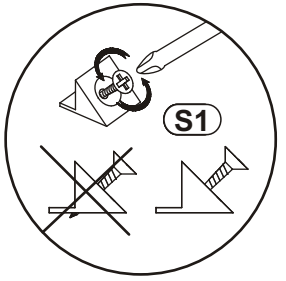
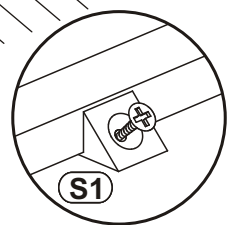
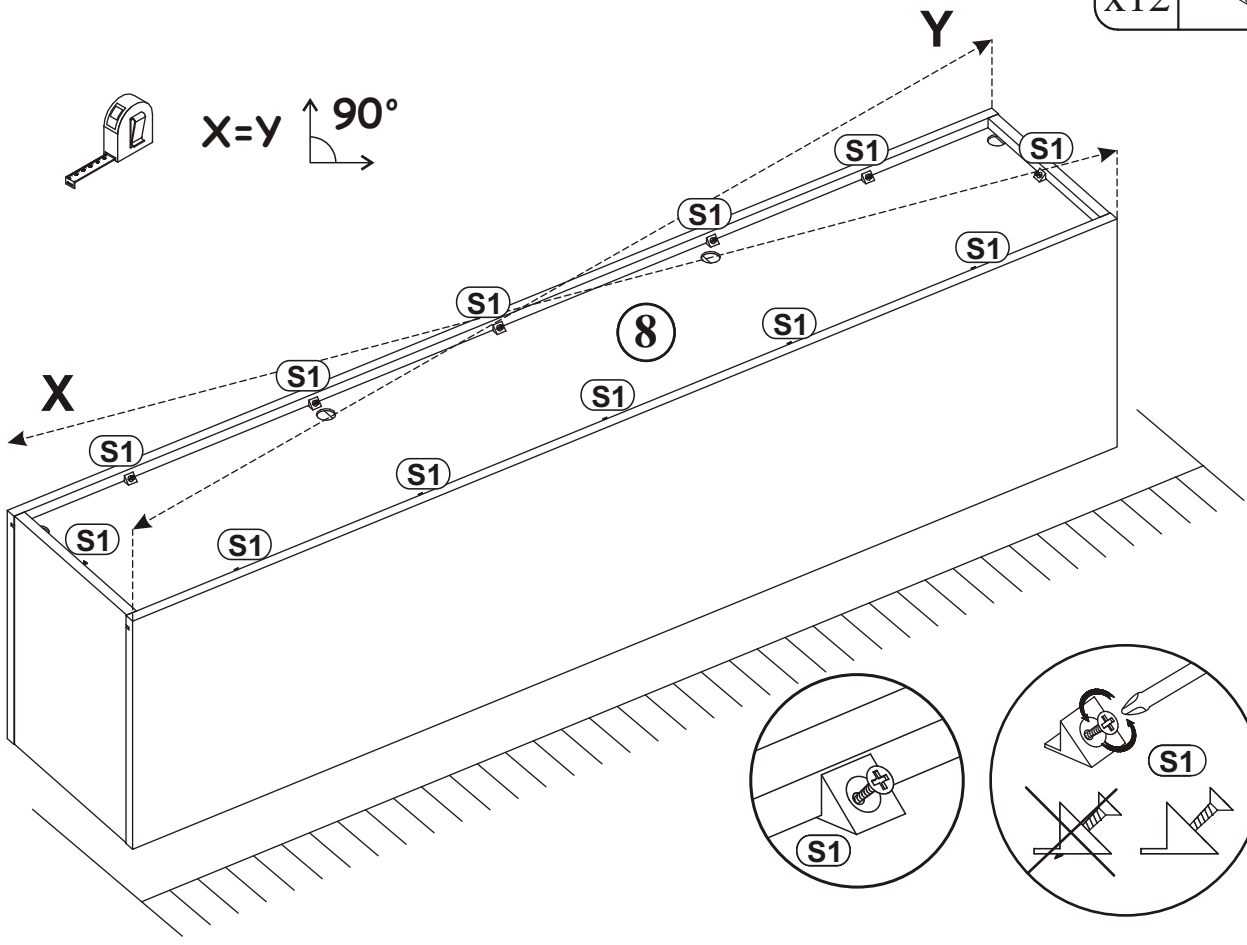

6

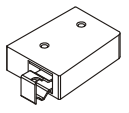
ZR1	
x4	

D6	
x8	USØ3,5x30

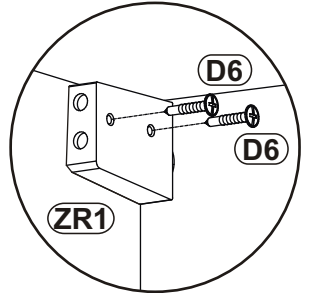
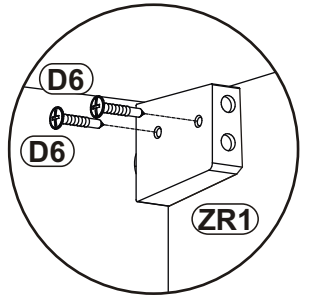
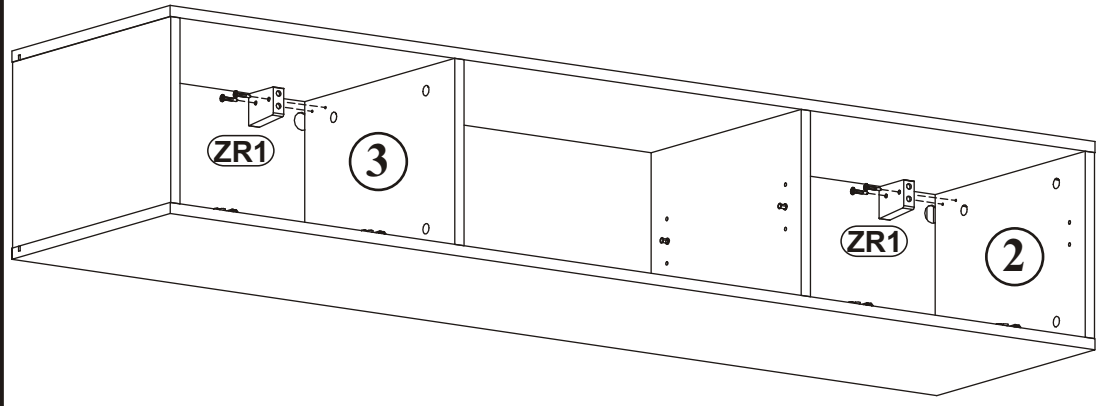
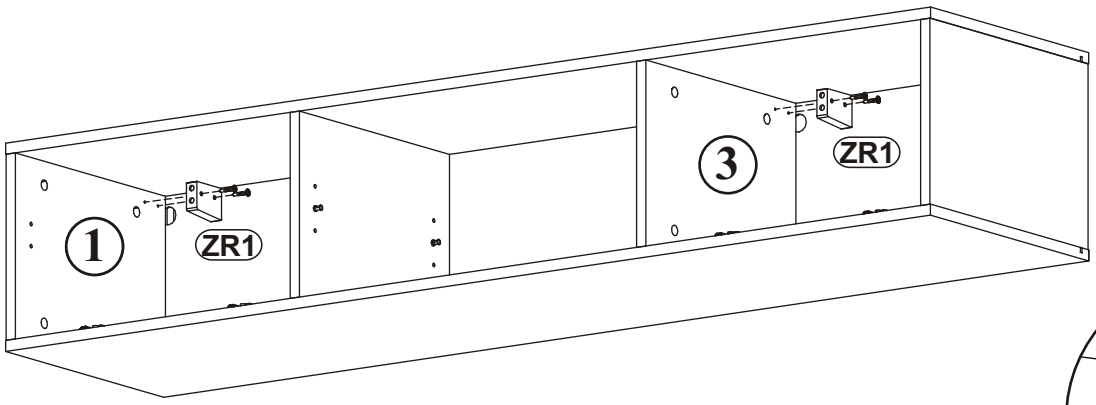

FLY TYP-33

7

T1		LED		D10	
x2		x1	x1	x4	USØ3,5x13

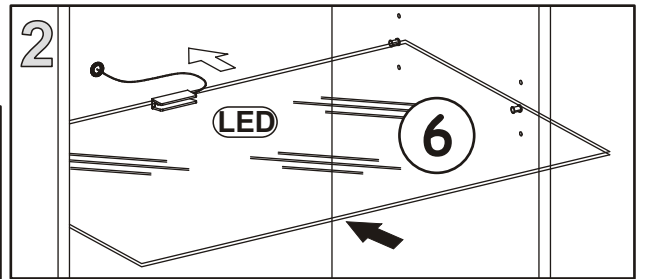
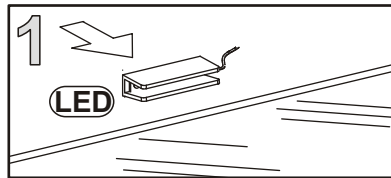
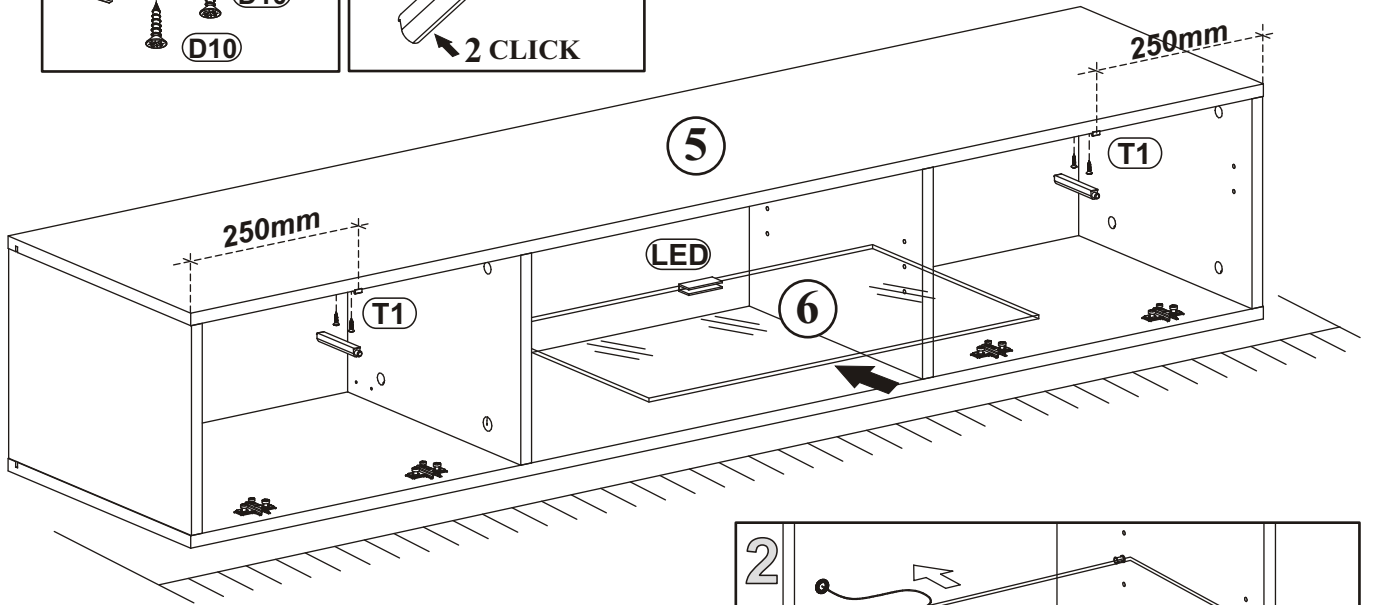
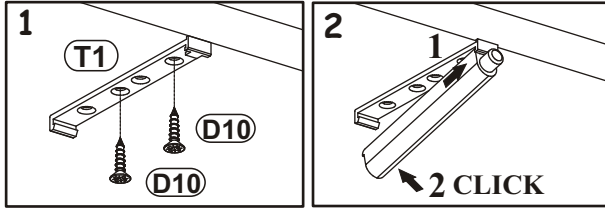

8

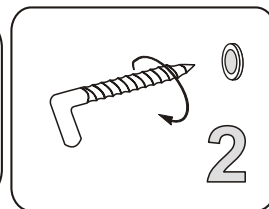
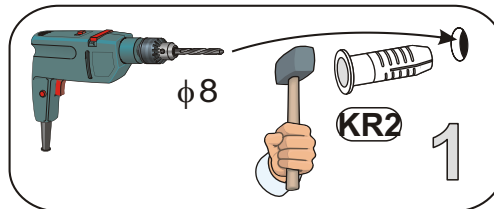
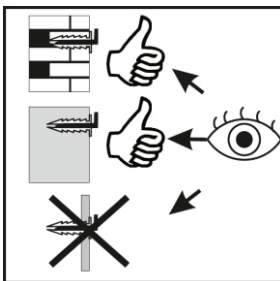

KR2	
x4	

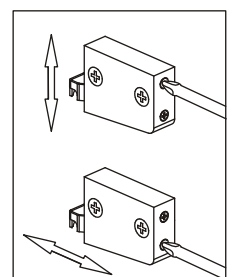
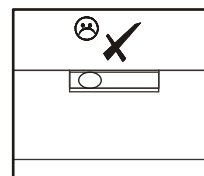
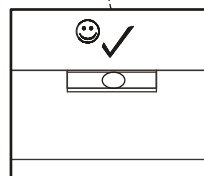
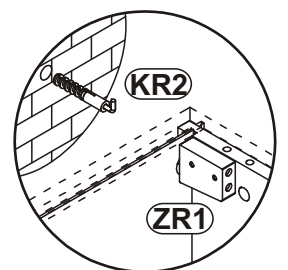
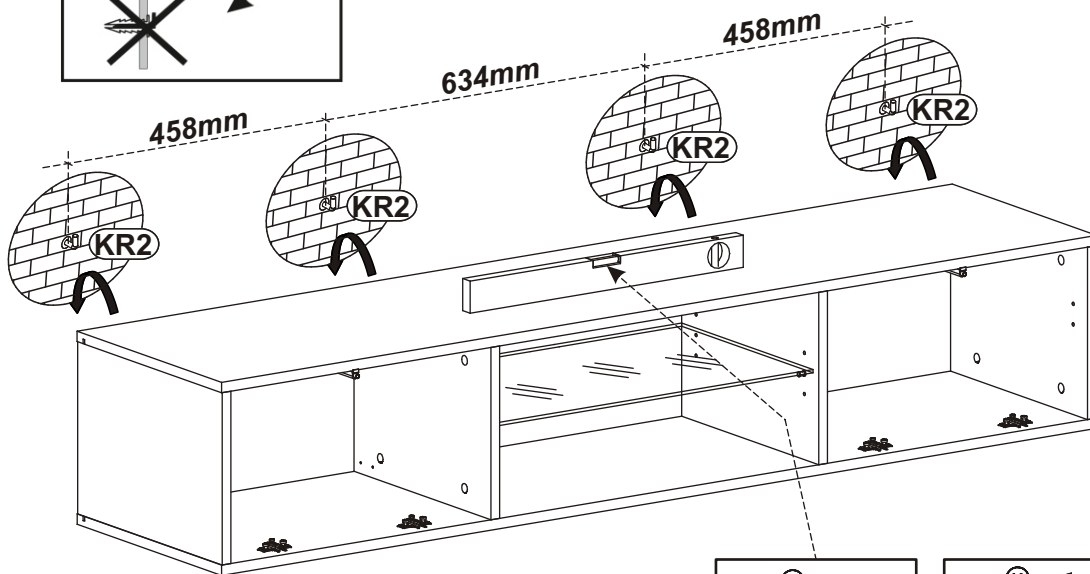

9

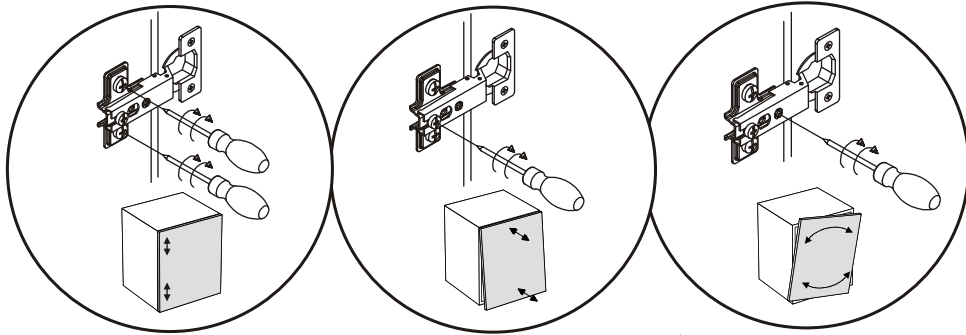
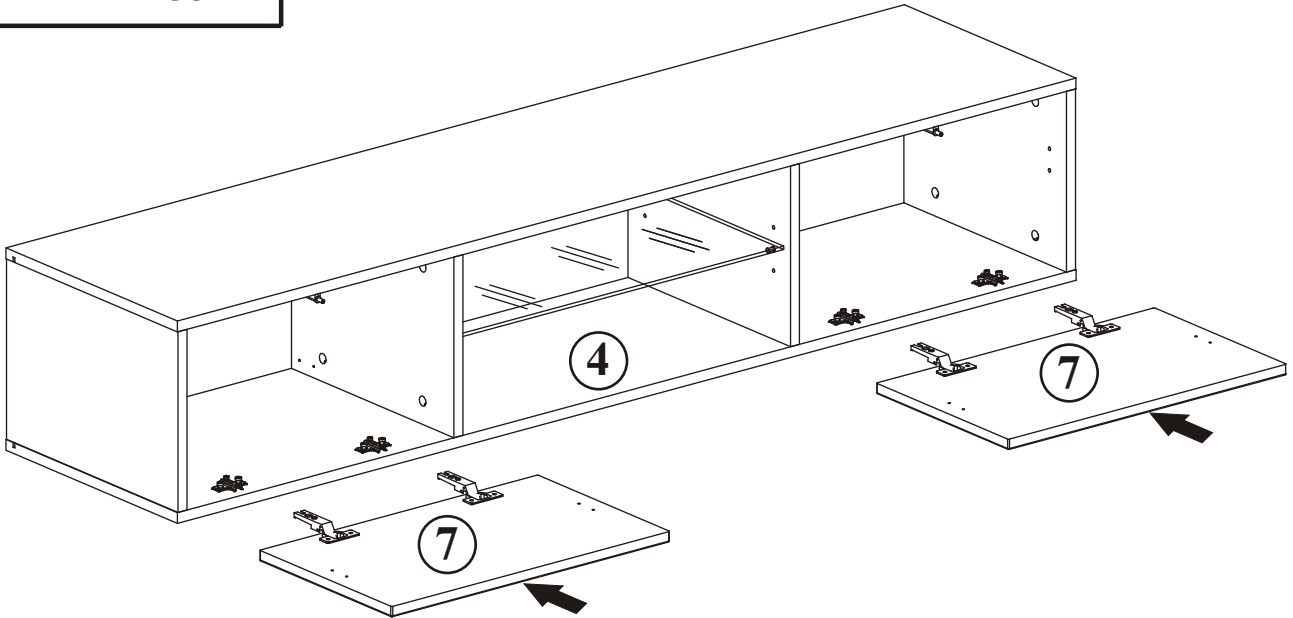

10

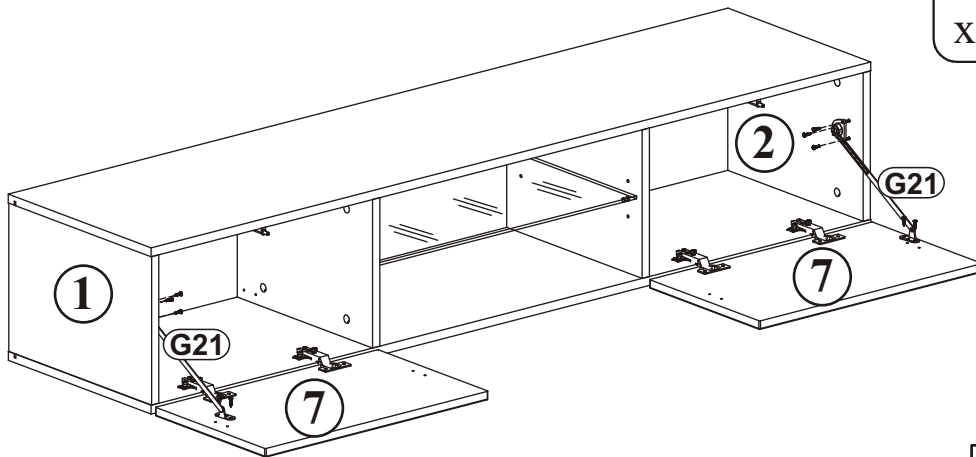

D10		G21	
x4	USØ3,5x13	x2	
D7			
x6	USØ3x16		

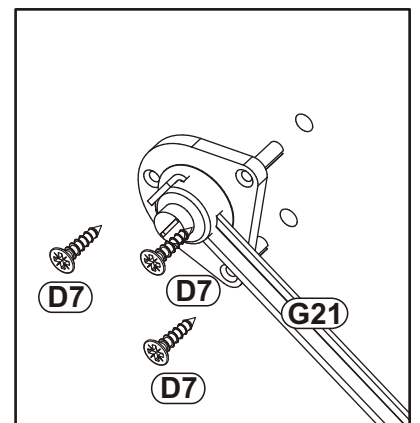
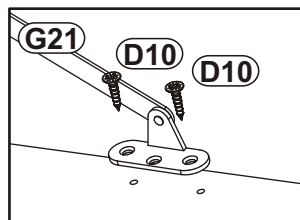

MODELL: PW MIX 23_MX Typ MX

1

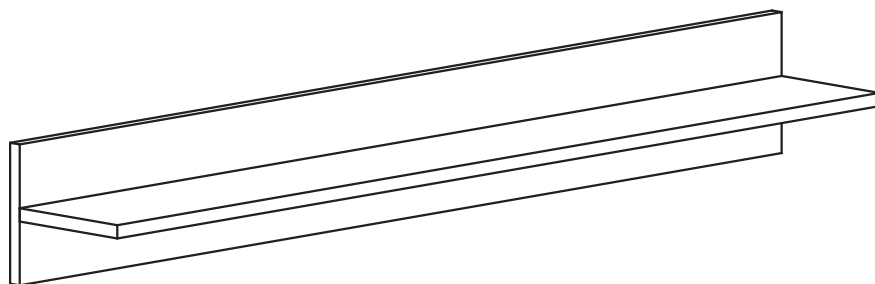

2

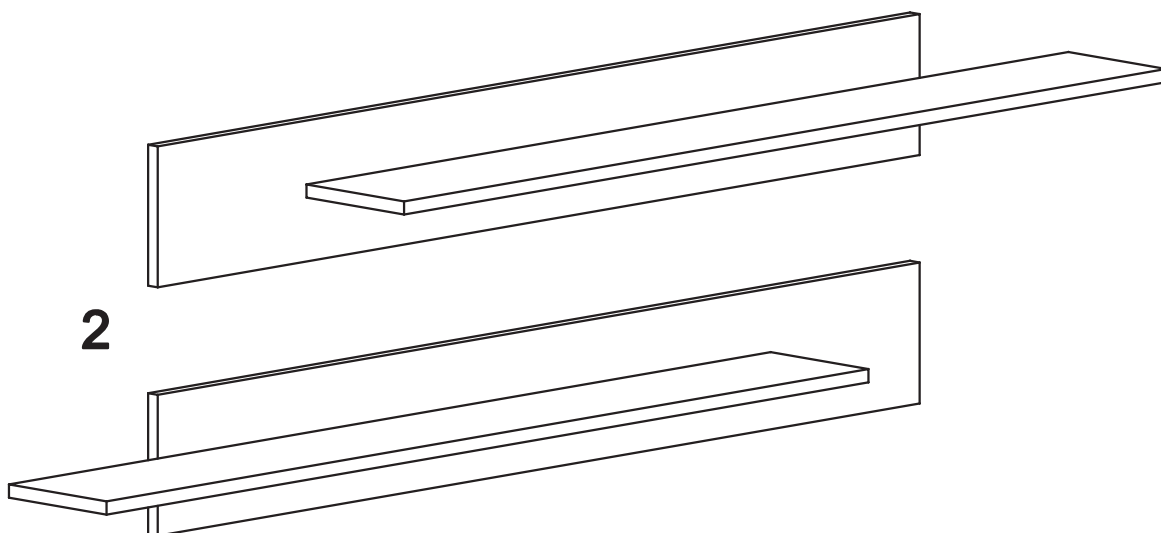

(D) Montageanleitung

(GB) Assembly instructions

(NL) Montage-instructies

(PL) Instrukcja montażu

(TR) Montaj Talimatları

(RU) Инструкция по монтажу

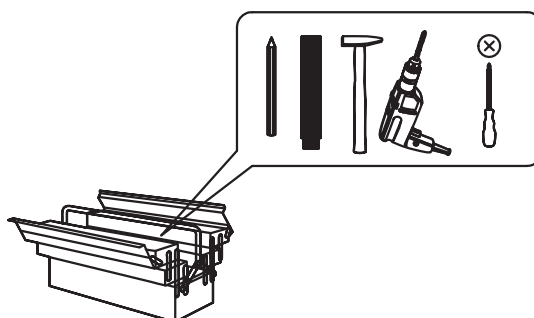

Sicherheitshinweise • Safety instructions • Veiligheidsinstructies •
Wskazówki bezpieczeństwa • Güvenlik uyarıları ? Правила техники безопасности

D	Bitte nur mit einem Staubtuch oder leicht feuchtem Lappen reinigen. Keine scheuernden Putzmittel verwenden.
GB	Please only clean with a duster or a damp cloth. Do not use any abrasive cleaners.
NL	Reinig alleen met een stofdoek of een lichtjes vochtige doek. Gebruik geen schurende poetsmiddelen.
PL	Czyszczenie należy wykonać wyłącznie za pomocą ściereczki lub lekko nawilżonego ręcznika. Nie stosować środków czyszczących do szorowania.
TR	Lütfen sadece bir toz beziyle veya hafif nemli yumuşak bir bezle siliniz. Aşındırıcı temizlik malzemeleri kullanmayınız.
RU	Очищайте от пыли тряпкой или слегка влажной ветошью. Не допускается применение чистящих средств, не предназначенных для ухода за мебелью.
D	Das Produkt ist nicht für die Anwendung im Freien geeignet.
GB	The product is not suitable for outdoor use.
NL	Het product is niet geschikt voor het gebruik in open lucht.
PL	Produkt nie jest przystosowany do zastosowań na wolnym powietrzu.
TR	Bu ürün açık havada kullanılmaya uygun değildir.
RU	Изделие не предназначено для использования вне помещений.
D	Überschreiten Sie die angegebenen Maximalbelastungen nicht. Andernfalls kann das Möbelstück beschädigt oder zerstört werden.
GB	Do not exceed the maximum loads specified. Otherwise, the furniture may sustain damage or be irreparably damaged.
NL	Overschrijd de aangegeven maximale belastingen niet. Anders kan het meubelstuk worden beschadigd of vernield.
PL	Nie wolno przekraczać podanych maksymalnych wartości obciążenia. W innym przypadku można mebel uszkodzić lub zniszczyć.
TR	Belirtilen azami yük değerini aşmayınız, aksi takdirde mobilya parçası zarar görebilir veya kullanılamaz hale gelebilir.
RU	Не допускается превышение указанных максимальных нагрузок. В противном случае возможно повреждение или разрушение мебели.
D	Schützen Sie Ihre Möbel generell vor Wasser (z.B. beim Wischen oder Blumen gießen). Die Feuchtigkeit kann in das Möbelstück eindringen und es beschädigen
GB	In general, keep water away from your furniture (e. g. when mopping or watering plants). The moisture may penetrate the furniture and damage it.
NL	Bescherm uw meubelen doorgaans tegen water (bijv. bij het dweilen of als u de bloemen water geeft). De vochtigheid kan in het meubelstuk dringen en het beschadigen.
PL	Mebel należy chronić przed wodą (np. podczas czyszczenia lub podlewania kwiatków). Wilgoć może wniknąć w mebel i uszkodzić go.
TR	Genelde mobilyalarınızı sudan koruyunuz (örneğin, yerleri paspaslarken veya çiçekleri sularken). Nem, mobilya parçasına nüfuz edebilir ve zarar verebilir.
RU	Предохраняйте мебель от попадания воды (например, при вытирании или поливке цветов). Не допускайте попадания влаги на мебель, чтобы предотвратить ее повреждение.
D	Der Artikel ist kein Kinderspielzeug! Lassen Sie Kinder auch nicht mit der Verpackung spielen. Sie könnten an der Folie ersticken oder sich an der Umverpackung verletzen.
GB	This product is not a toy! Do not allow children to play with the packaging. They could suffocate in the foil or injure themselves on the packaging.
NL	Het artikel is geen speelgoed voor kinderen! Zorg ervoor dat kinderen ook niet met de verpakking spelen. Ze kunnen stikken door de folie of zich verwonden aan de verpakking.
PL	Produkt nie służy do zabawy! Dzieci nie powinny bawić się opakowaniem produktu, gdyż mogą się udusić folią lub skaleczyć opakowaniem.
TR	Bu ürün bir çocuk oyuncakı değildir! Çocukların ürün ambalajlarıyla oynamalarına asla müsaade etmeyiniz. Çocuklar, folyo nedeniyle boğulabilir veya ambalaj nedeniyle yaralanabilirler.
RU	Не допускается игра детей с изделием! Не разрешайте детям играть с упаковочным материалом. Дети могут задохнуться в упаковочной пленке или пораниться упаковочным материалом.

Service • Dienstverlening • Serwis • Servis • Сервисная служба	
Name • Naam • Nazwa • Isim • Название	
Nr • No. • Номер	
Typ • Type • Тип • Тип	

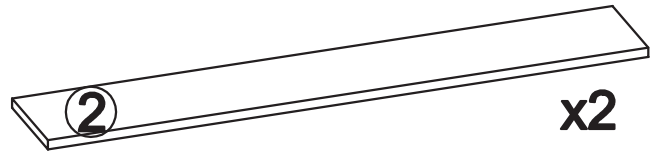
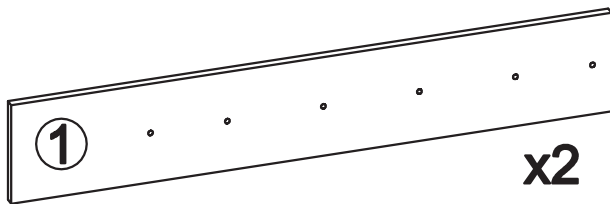

1

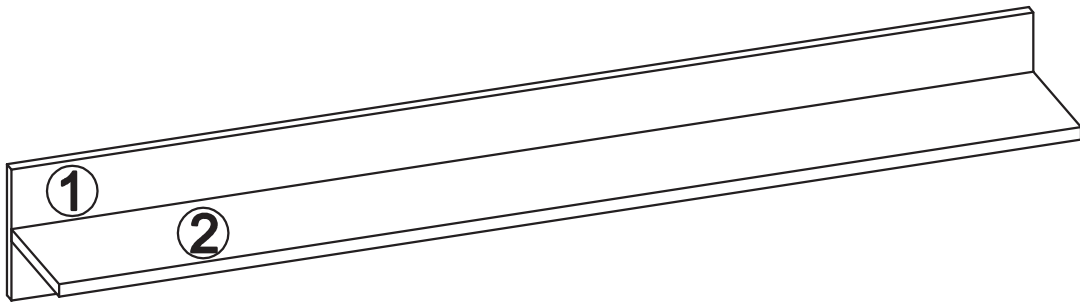

2

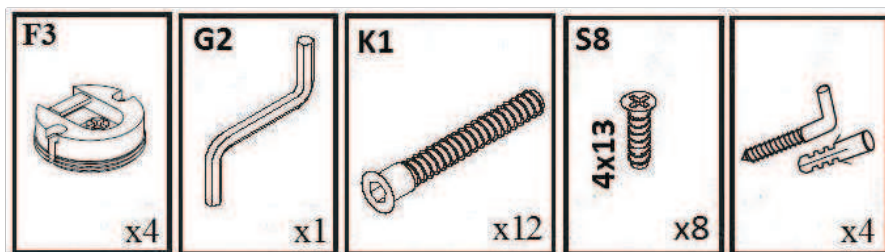
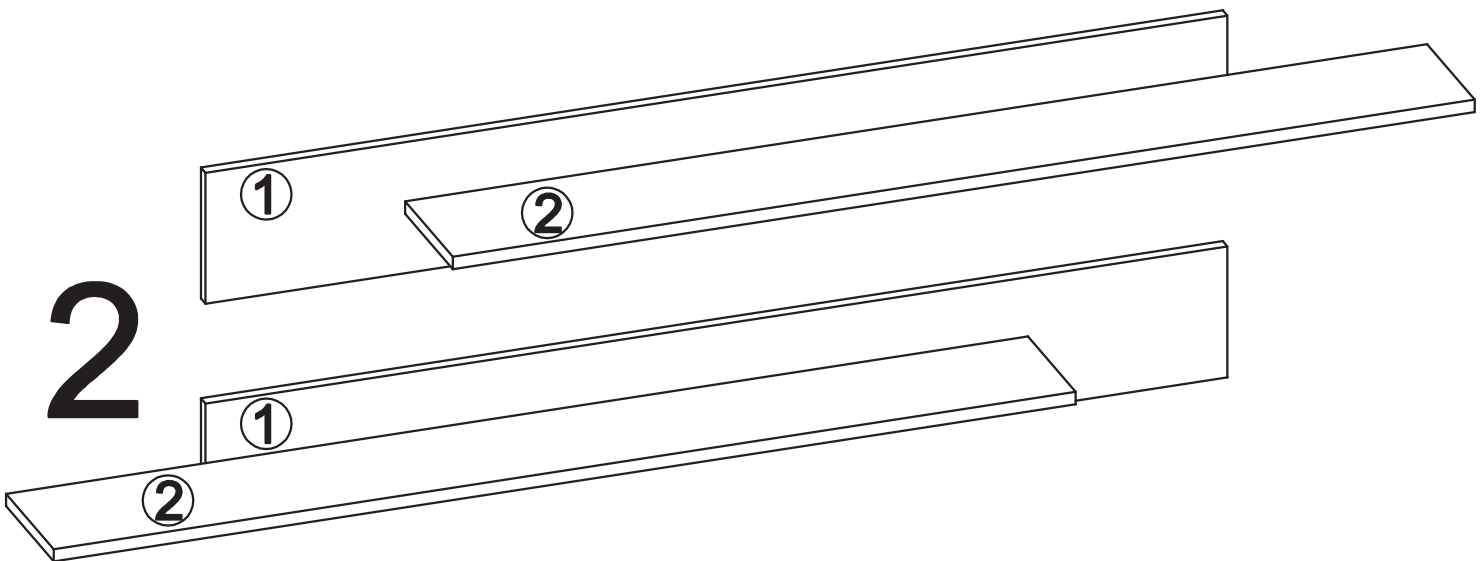

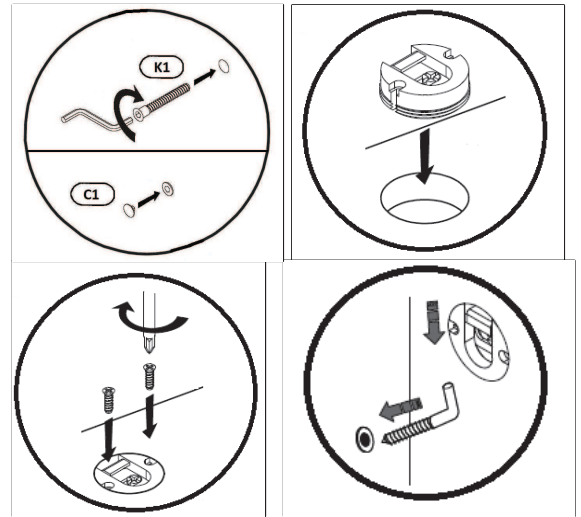
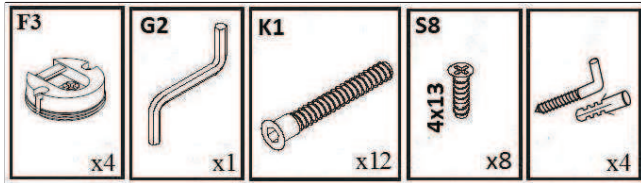
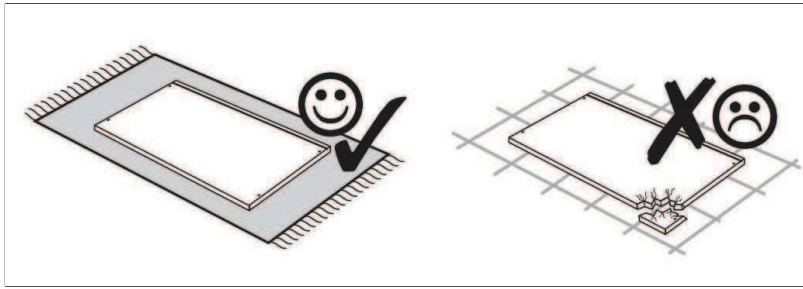

1

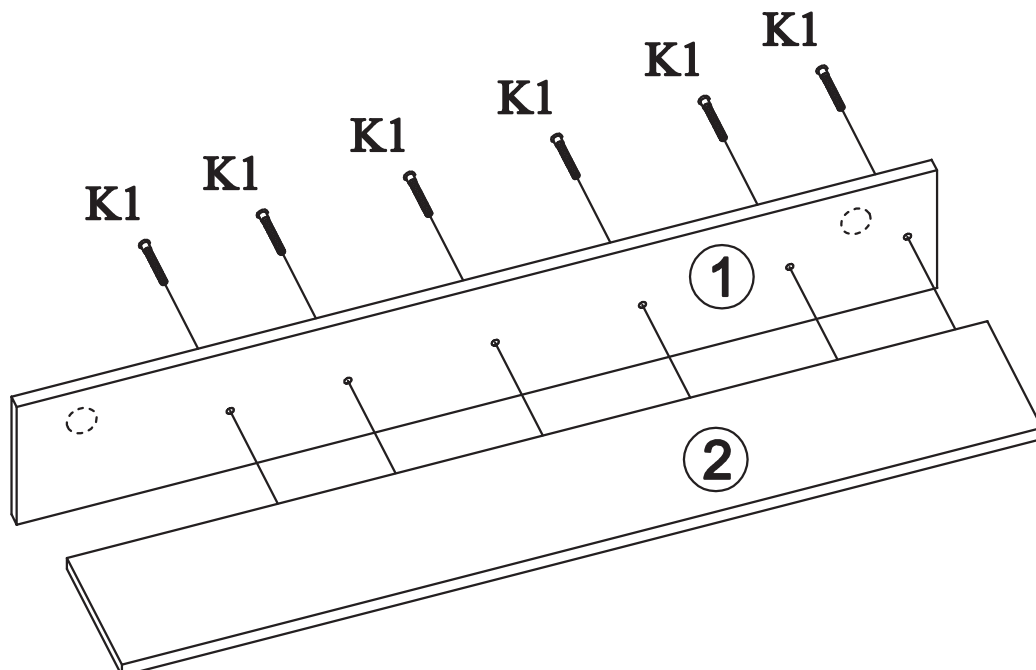
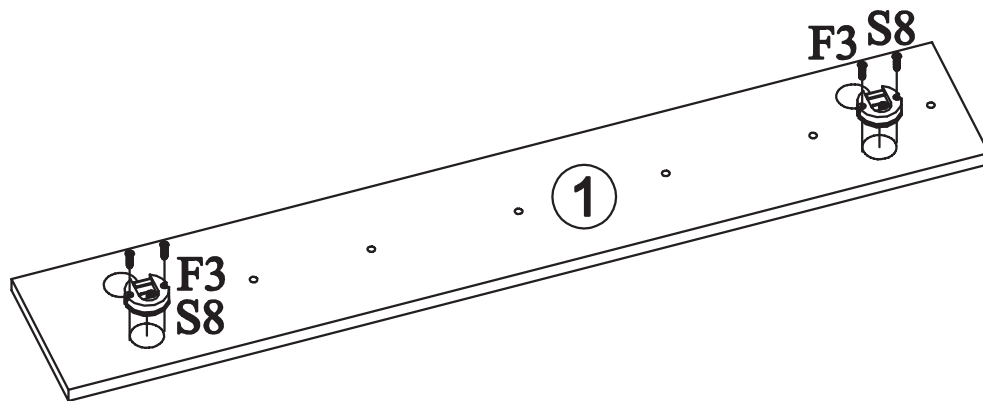
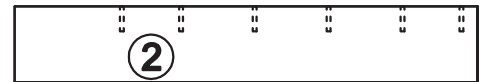
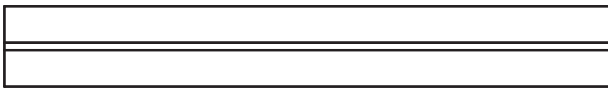

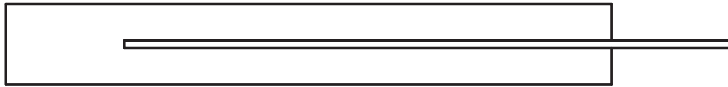
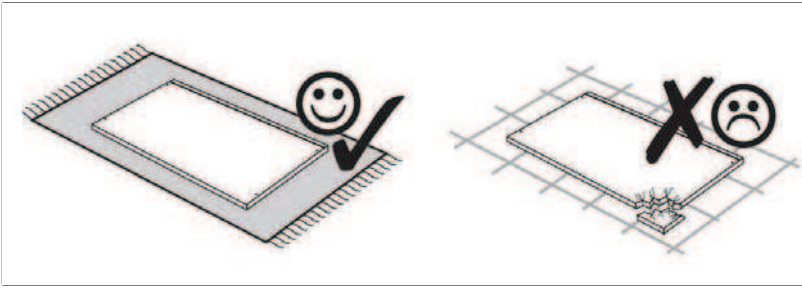

2

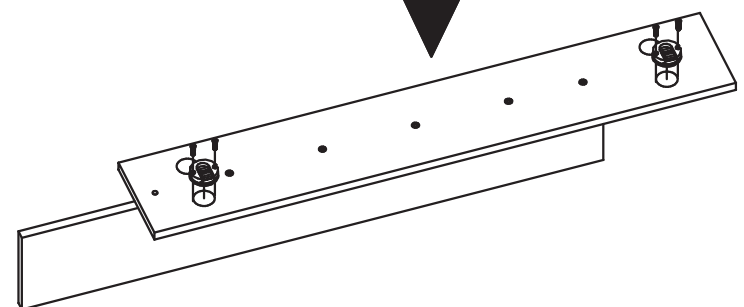
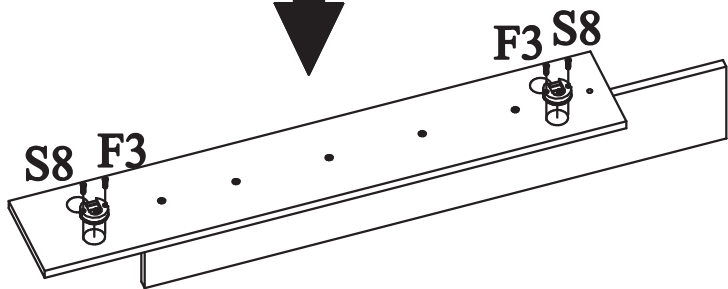
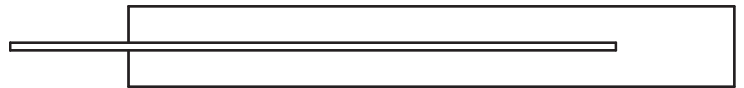
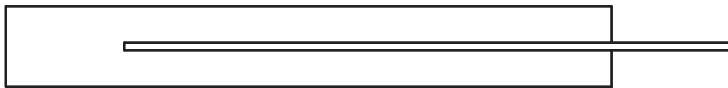
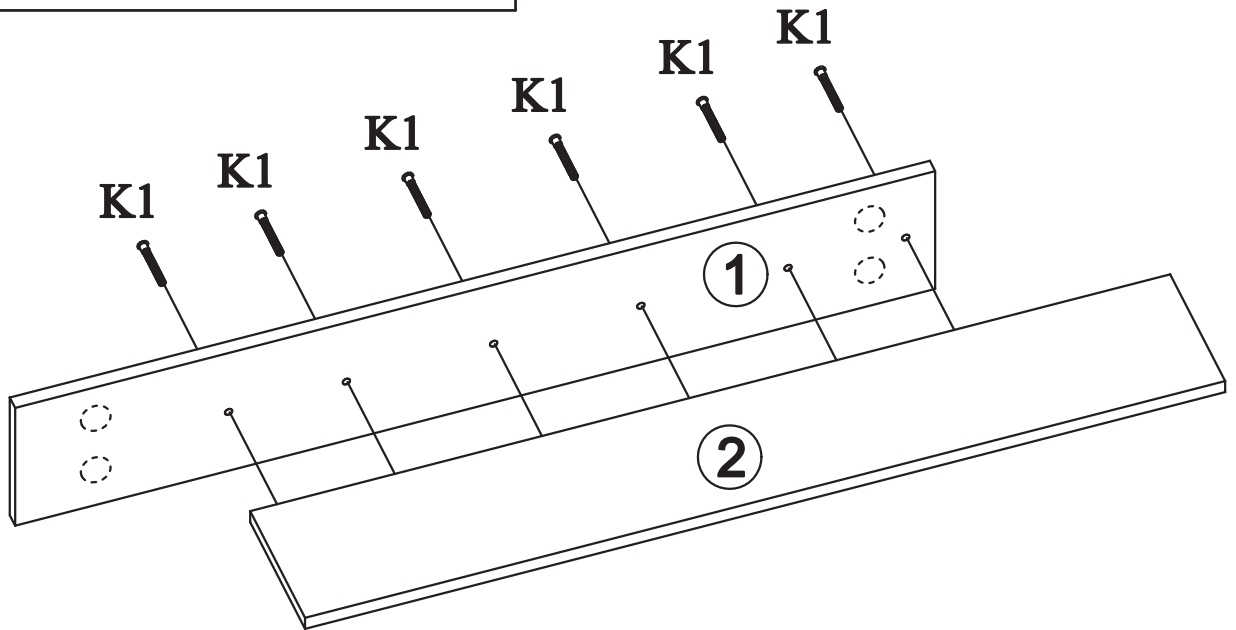
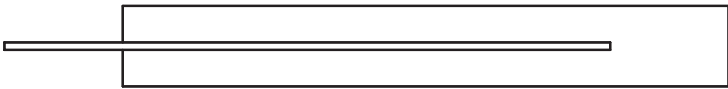
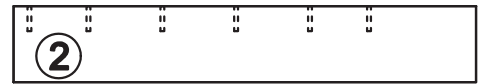
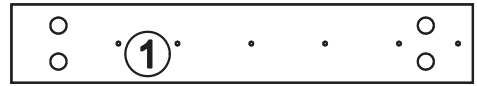

Modellname: **FLY**
Nazwa modelu:

Modellreihe: **23 -- FL**
Numer modelu:

21

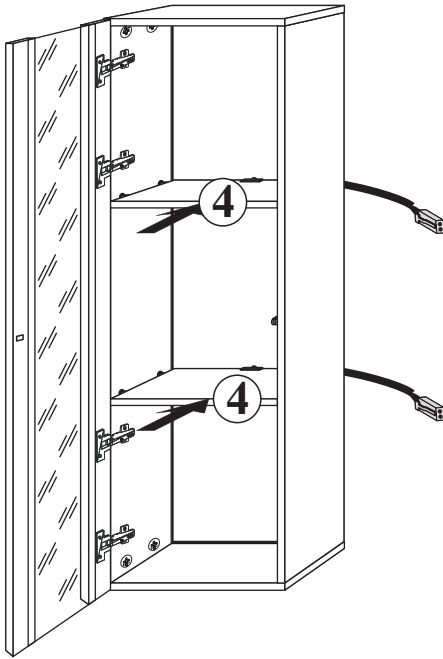

22

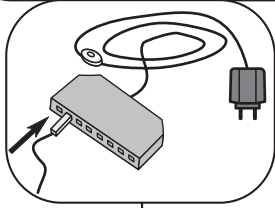
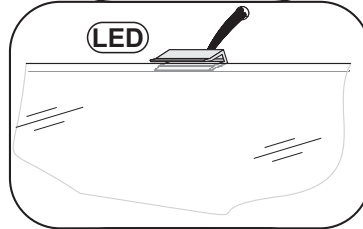
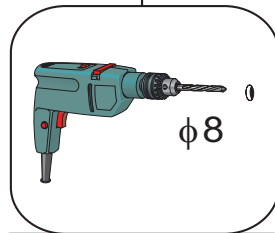
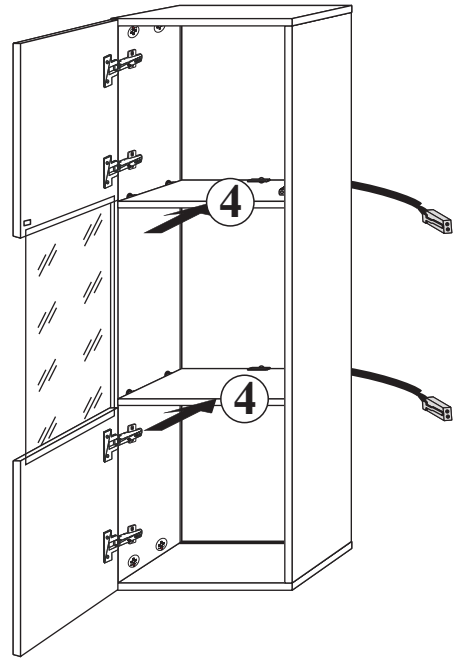

41

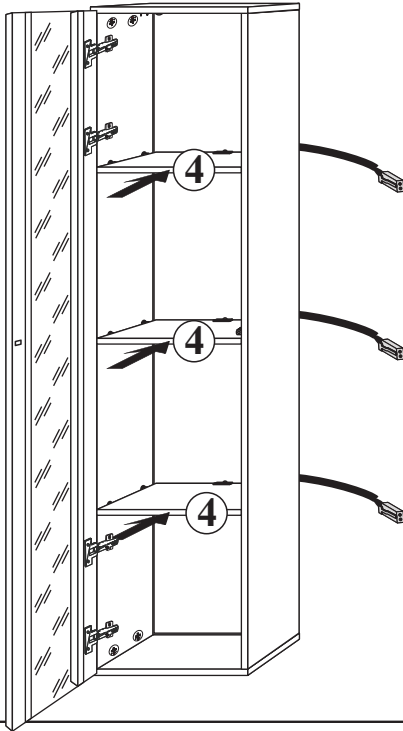

42

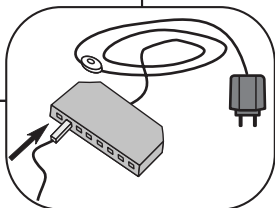
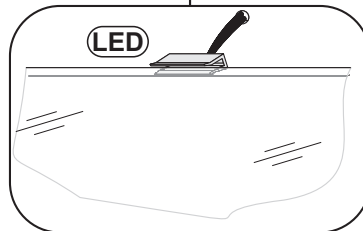
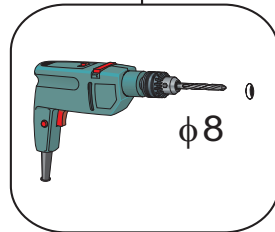
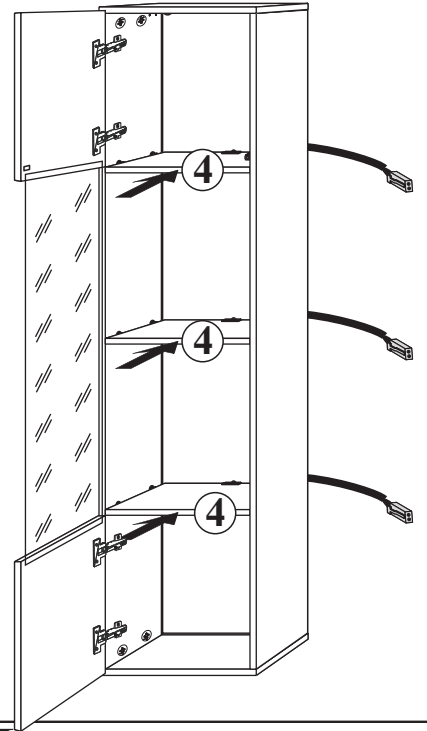

SBI

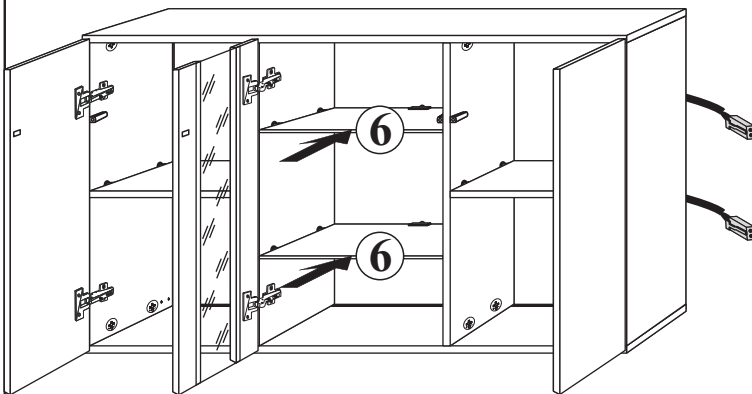

SBII

